

## European Wind Energy Conference (EWEC 2010)

# Reliability Analysis and Prediction of Wind Turbine Gearboxes

K. Smolders  
Hansen Transmissions International, Belgium  
[KSmolders@HansenTransmissions.com](mailto:KSmolders@HansenTransmissions.com)

H. Long (Corresponding Author)  
Durham University, England  
[Hui.Long@Durham.ac.uk](mailto:Hui.Long@Durham.ac.uk)

Y. Feng  
Durham University, England  
[Yanhui.Feng@Durham.ac.uk](mailto:Yanhui.Feng@Durham.ac.uk)

P. Tavner  
Durham University, England  
[Peter.Tavner@Durham.ac.uk](mailto:Peter.Tavner@Durham.ac.uk)

## Abstract

This paper presents a reliability analysis model of wind turbine gearboxes by developing a generic gearbox configuration and modular structure. It encapsulates all the reliability critical components within the gearbox subsystem in a wind turbine. Reliability block diagrams of gearbox modules and components have been established by using Relx Reliability Analysis software. Failure rates of the critical components are estimated by applying existing industrial standards and datasheets for general mechanical applications. Results of failure rates and reliability of three generic gearbox configurations have been obtained. To improve the reliability prediction of wind turbine gearbox, an advanced prediction model based on failure modes and load carrying capability of individual components under operational conditions has been discussed. This research has highlighted the importance of validation of the reliability prediction models using available field failure data, which could be only possible through collaborations of wind farm owners, WT manufacturers, gearbox manufacturers, and bearing manufacturers.

**Keywords:** Wind Turbine, Gearbox, Reliability.

## 1 Introduction

Wind energy has a great potential to make an important contribution towards the EU's targets of achieving at least 20% of the EU's energy demand using renewable energy by 2020. To

achieve a better efficiency of wind turbines and to reduce the cost of wind energy, the deployment of new designs with reduced maintenance requirements and increased reliability is an important consideration for future development, especially for offshore wind turbines.

The gearbox is one of the important subsystems in an indirect drive wind turbine (WT) providing the functions of transferring power from the low speed turbine shaft at high torque to the high speed generator shaft at low torque. A wind turbine is capital-intensive, the gearbox alone counts for about 13% of the overall cost of a 5MW wind turbine [1]. The field reliability study of modern wind turbines shows a reduction in failure rates of the gearbox subsystem in comparison with other subsystems [2]. However, the gearbox has a low availability due to its high downtime per failure and gearbox failure incurs high costs for repair. As a conventional mechanical system, the design of traditional gear transmissions has been well documented in the International Standards [3]. However, for gear systems used in the wind turbine applications [4], the demand for gearboxes designed with extremely high gear ratios and operating under conditions subject to a broad spectrum of load and speed variations makes the reliability prediction and failure prevention difficult. Current research initiatives in this area include the Gear Reliability Collaborative (GRC) of US NREL/DOE [5] and the RELIAWIND Consortium of EU FP7 [6], which have committed research efforts to tackle this challenging problem.

An important method in reliability analysis appropriate at the design stage is Failure Mode, Effects and Criticality Analysis (FMECA). It

provides benefits to improve designs by identifying weaknesses in subassemblies and components of a complex system. Identification of weak points in design also prompts further improvement in the configuration design of the system. More importantly, through the identification of less reliable components and associated potential failure modes and causes, corrective actions can be taken in the early development phase and preventive maintenance strategies can be initiated. Commercial reliability analysis software Relex [7] enables the FMECA to be carried out but also provides functions in reliability prediction through Reliability Block Diagram (RBD), Fault Tree and Markov Modelling, which are suitable for wind turbine reliability studies.

This paper reports research development to construct a reliability analysis model by developing a generic gearbox configuration and modular structure which encapsulates all the reliability critical components within the gearbox subsystem in a WT. Reliability block diagrams of gearbox modules and components have been established by using Relex Reliability Analysis software. Failure rates of the critical components are estimated by applying existing industrial standards and datasheets for general mechanical applications. Results of failure rates and reliability of three generic gearbox configurations have been obtained. To improve the reliability prediction of wind turbine gearbox, an advanced prediction model based on failure modes and load carrying capability of individual components under operational conditions has been discussed.

## 2 Generic Configurations and Modular Definition of WT Gearbox

The main function of the WT is to extract kinetic energy from the wind and to transform it into electrical energy by transmitting power via the drive train from low speed and high torque to the generator operating at high speed and low torque. The WT is typically designed to fulfill this task over a design life of 20 years. The function of the gearbox is to transmit power at low speed and high torque from the rotor to the generator operating at high speed and low torque. To fulfill this task during the life span of a wind turbine the gearbox must:

- increase the low speed of the slow rotating turbine to the high speed of the generator;
- compensate for the torque differences across the gearbox resulting from variations in speed;
- remain functional for 20 years under dedicated and acceptable maintenance.

### 2.1 Gearbox Configurations

In order to develop a better understanding of reliability performance of different WT designs, this paper considers two generic WT configurations - they are pitch regulated upwind WTs with active yaw control. The characteristics of the two WT configurations, R80 and R100, are being used by Reliawind and are detailed in Table 1 [6].

Characteristic	R80	R100
Nominal Power (MW)	1.5~2.0	3.0~5.0
Rotor Diameter (m)	80~90	120~130
Hub Height (m)	60~100	100~120
Rotational Speed (rpm)	10~20	14~15
Aerodynamic Breaks	full feathering	full feathering
Operating Temperature	-25~40 °C	-25~40 °C
Number of Blades	3	3

Table 1: characteristic of WT configurations

Within the R100 design, two sub-configurations are considered, with either a synchronous generator (R100-S) or an asynchronous generator (R100-A). This results in three gearbox configurations, namely GB-R80, GB-R100-S and GB-R100-A:

**GB-R80:** a combination of one planetary stage followed by two parallel stages with a transmission ratio of approximately 100.

**GB-R100-S:** a combination of one planetary stage of spur gears followed by one planetary stage of helical gears with a transmission ratio of approximately 35.

**GB-R100-A:** a combination of two planetary stages followed by one parallel stage with a transmission ratio of approximately 126.

To enable reliability modelling using reliability prediction and reliability block diagrams, a breakdown structure based on modular composition has been developed for the considered gearboxes. This breakdown structure represents the gearbox system containing all subassemblies and corresponding components which are considered to be critical to reliability performance of a WT gearbox.

### 2.2 Gearbox Modular Structure

Due to the required large transmission ratio, a gearbox typically consists of two or three stages, either planetary or parallel, to increase the speed. These stages are encapsulated within a gearbox housing securing individual components. In general, properly designed torque arms are integrated in the gearbox housing to reduce excess torque. Additionally a lubrication system

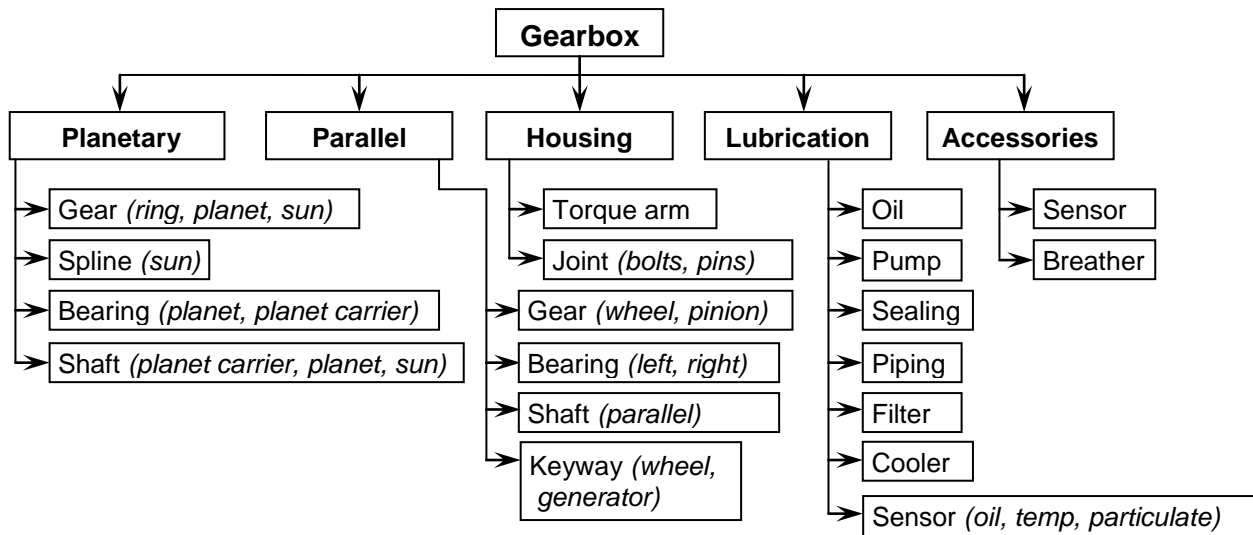

Figure 1: modular definition of WT gearbox

and sensors are in place to provide proper lubrication and to monitor important parameters. By referencing to existing WT classifications [4, 8] and two classifications under development [9, 10], the definition of a modular structure of a gearbox for a WT is developed, as shown in Figure 1.

The definition adopted uses the terminology in the draft version of IEC 61400-4 (ISO 81400-4) [4] to name components of planetary stage and parallel stage modules. Depending on the torque to be transmitted, different designs of a planetary stage may be employed, such as simple planetary (each planet shaft carries one planet gear) or compound planetary (one planet shaft carries two planet gears). The first planetary stage may be followed either by another planetary stage or a parallel stage. Based on the speed of a shaft, it is often referred to as the low speed shaft (LSS), the intermediate speed shaft (ISS) or the high speed

shaft (HSS). Types of gears used for these stages can be spur or helical gears. Bearings are specified by referring to the shaft and the position where they are located, for example, at the rotor side (RS) or generator side (GS).

Applying the developed modular structure and the definitions, Figure 2 illustrates two generic WT gearbox configurations considered in this paper, GB-R80 (one planetary stage and two parallel stages) and GB-R100-A (two planetary stages and one parallel stage) [6]. The diagrams illustrate the layout of the stages and give details at modular level, such as Low Speed Shaft (LSS), Low Speed Sun gear (LS-SUN), Planet Shaft (PS), Low Speed Intermediate Shaft (LS-IS), High Speed Intermediate Shaft (HS-IS), and High Speed Shaft (HSS). Further details of each module at component level can be specified in order to carry out reliability modelling.

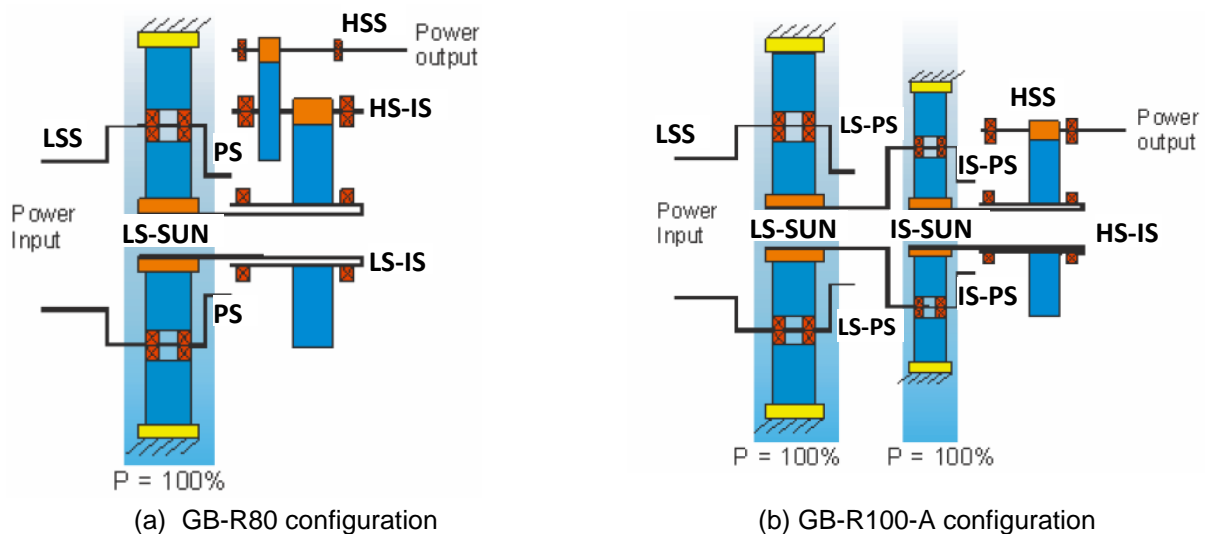

Figure 2: illustration of two modular gearbox configurations

### 3 Gearbox Reliability Prediction

#### 3.1 Estimation of Mean Time to Repair and Failure Rate at Modular Level

In order to assess the reliability of a gearbox and its effects on the overall performance of a WT, the statistics related to the failure of individual components and times to repair of certain modules of a gearbox are required.

In this paper, the repair time is defined as the actual time used to repair or replace a component. This implies that logistic delays and transportation times are excluded from the repair time. Therefore, it can be regarded as the minimal downtime required to perform the actual repair or replacement. In general, the statistics of the times to repair of certain components or modules can be derived from service data. Depending on the quality of service data it may be possible to estimate repair times of critical components related to specific failure modes, or it might be only possible to estimate repair times of different modules or even only of the overall gearbox. In the absence of field service data a rough estimation of the mean time to repair (MTTR) of the different modules is assumed as shown in Table 2.

Module	MTTR (hour)
LS Planetary	12
IS Planetary	12
LS-I Parallel	12
HS-I Parallel	6
HS Parallel	6
Housing	12
Lubrication System	4
Accessories	1

Table 2: estimated values of MTTR of main modules

For the prediction of failure rates, in the absence of field data of component failure rates, this paper has adopted procedures and data provided in the "Handbook of Reliability Prediction Procedures for Mechanical Equipment" of the Naval Surface Warfare Center (NSWC07) [11]. By choosing the appropriate subcategory for each component, a dedicated failure rate prediction formula can be obtained. For some of the critical components as identified in Figure 1, NSWC07 provides different formulae and associated datasheets to predict failure rates of these components. To illustrate the procedure of failure rate prediction provided in NSWC07 and used in this paper, the formula given for gear failure,  $\lambda_G$ , under specific operational conditions is shown below [11]:

$$\lambda_G = \lambda_{G,B} C_{GS} C_{GP} C_{GA} C_{GL} C_{GT} C_{GV} \quad (1)$$

Using multiplication factors, this formula considers the base failure rate of the gear ( $\lambda_{G,B}$ ), operating

speed deviation with respect to design speed ( $C_{GS}$ ), actual gear operating loading with respect to design load ( $C_{GP}$ ), misalignment ( $C_{GA}$ ), actual viscosity of lubricant with respect to the specified viscosity in design ( $C_{GL}$ ), the operating temperature ( $C_{GT}$ ), and the AGMA Service Factor ( $C_{GV}$ ). For bearings, the following formula is recommended by NSWC07 [11]:

$$\lambda_{BE} = \lambda_{BE,B} C_y C_n C_{CW} C_t \quad (2)$$

Where  $\lambda_{BE}$  is the failure rate of the bearing under specific operation conditions, calculated by using the base failure rate of the bearing  $\lambda_{BE,B}$  and the multiplication factors by considering the applied load  $C_y$ , the lubricant  $C_n$ , water contamination  $C_{CW}$ , and the operating temperature  $C_t$ .

For a gearbox used for a wind turbine application, which subjects to a broad spectrum of load and speed variations, appropriate values of multiplication factors need to be assumed in order to estimate the gear and bearing failure rates. Similar formulae for splines and shafts can also be obtained from NSWC07 and have been used to estimate failure rates of these components in this paper. For other components as specified in Figure 1, such as keyways, sealing, filters, etc. a specific failure rate can be assumed for each component in order to predict the total failure rate of the gearbox. Using datasheets available in NSWC07 and considering failure rates of gearboxes published by Spinato, Tavner et al [2], a rough estimation of failure rates of components is made to predict failure rates at modular level, Table 3 shows an example of R80 LS planetary.

Components of R80 LS Planetary Module	Failure Rate (failures/year)	Quantity
LSS	0.0025	1
LSS Bearing RS	0.00009	1
LSS Bearing GS	0.00009	1
LS-PS	0.0025	3
LS-PS Bearing	0.00022	3
LS-PS Wheel	0.00017	3
LS Ring Wheel	0.00017	1
LS Sun Pinion	0.00017	1
LS Sun Shaft	0.0025	1
LS Sun Shaft Spline	0.00025	1
Total:	0.01444	

Table 3: estimated failure rate of R80 LS planetary

#### 3.2 Prediction of Failure Rate of Gearbox

From a reliability point of view, a WT gearbox can be regarded as series of connected modules. The reliability block diagram (RBD) can be therefore easily obtained as a serial connection of all the components in the modules of the gearbox. This implies that there is no redundancy in a WT gearbox. Figure 3 shows RBDs for three gearbox configurations GB-R80, GB-R100-S and GB-R100-A at modular level.

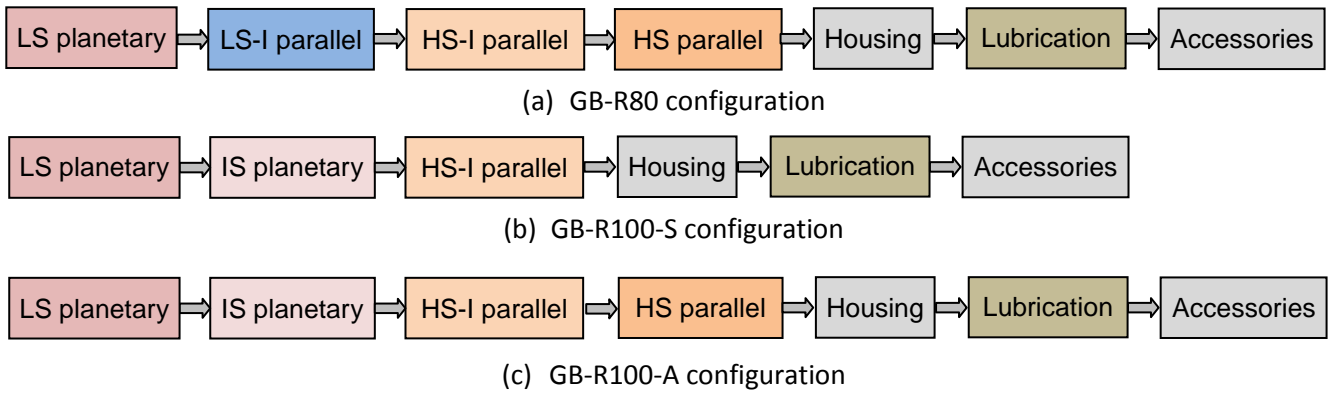

Figure 3: reliability block diagrams of considered gearboxes

Based on the assumptions of the failure rates of individual components, the total failure rates at modular level, such as LS planetary, LS-I parallel, HS parallel etc. as shown in Figure 3, can be obtained. Using the reliability block diagrams, reliability predictions using Relex and its built-in models have been carried out to derive total failure rates of three generic gearbox configurations considered in this paper. In the future, if the field data of component failure rates and modular mean time to repair becomes available, they can be fed into the developed Relex models such that the failure rates and reliability predictions can be updated to more realistic values. As an example, Figure 4 gives predicted failure rates of individual modules of three gearbox configurations considered. Figure 5 compares the total failure rates of three gearbox configurations. Please note that the results presented in Table 3, Figures 4 and 5 are derived from a mathematical reliability prediction based on Relex models using general industrial formulae and assumptions. They are by no means originating from field failure data.

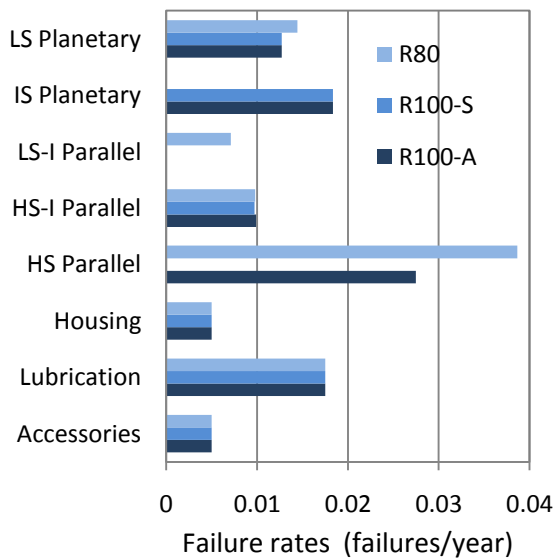

Figure 4: predicted failure rates of individual modules

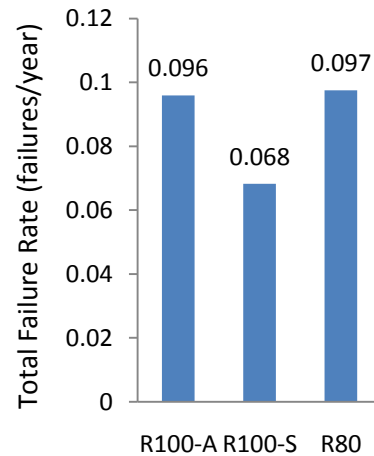

Figure 5: predicted total failure rates of three gearboxes configurations

As shown in Figure 5, the relative ranking of three gearbox configurations considered with respect to the total failure rates suggests that the GB-R100-S is the most reliable configuration. This could be expected since this gearbox configuration has the least components therefore the failure rate at the gearbox subsystem level is reduced. From the results of failure rates of individual modules as shown in Figure 4, the following are some observations:

- For the GB-R80 and the GB-R100-A configurations the high speed parallel stage is found to be the most unreliable module. Since the GB-R100-S does not have this high speed stage as shown in Figure 3, its reliability improves compared with the other configurations.
- It seems that a planetary intermediate speed stage is less reliable than a parallel intermediate speed stage. This could be that a parallel stage consists of fewer components compared to a planetary stage.
- The planetary intermediate speed stage seems less reliable than the planetary low speed stage. This can be explained by the fact that the prediction model relates the reliability of bearings to the operating speed.

Since the intermediate stage has a higher speed, its reliability will be lower.

- The prediction results also show that the lubrication subsystem has an important effect on reliability. However the housing and the accessories are the least critical components from a reliability point of view.

## 4 Discussions

The outlined procedure in Section 2 and 3 provides a useful methodology for gearbox reliability prediction. For the estimation of component failure rates, the formulae used for components like gears and bearings are the only prediction formulae available in Relex software. It is worth pointing out that these formulae and associated data have not been validated for wind turbine gearboxes nor have they been derived for this specific application. Failure rate predictions and interpretations based on these procedures should therefore be considered in context.

In addition, Relex software by default assumes a constant failure rate for all components. This implies that the reliability of mechanical components is assumed to follow an exponential distribution. However, it is well known in literature that mechanical components suffer from wear out and that a constant failure rate is far from an accurate reliability distribution.

It is important to understand that reliability can be measured using field failure data through Life Data Analysis (LDA) or Weibull Analysis. It would provide the best reliability prediction based on LDA of field failure data of identical or similar components with adjustments according to the actual operating conditions such as load and speed of the considered component. However, in the absence of accurate field failure data of the different components, it is only possible to provide a high level update using failure rate measurements of gearbox assemblies. This limits the applicability of the reliability analysis up to gearbox level at the best since no validation of the reliability predictions of the individual components is possible.

These issues may be addressed by developing advanced reliability prediction methods and one possible model for reliability prediction is discussed below. To illustrate the procedure of the analysis, gears are selected to relate load carrying capability, failure modes and reliability calculations. Mechanical components typically fail over time due to fatigue mechanisms: due to cyclic loading inducing mechanical stresses, deformations, temperature gradients. With time varying amplitudes of loading applied to mechanical components it causes the material properties to degenerate over time leading to

failures. The number of cycles which can be endured by a certain component is typically assessed using S/N curves. These curves express the number of load cycles a component or material can endure at certain constant amplitude of loading before a certain probability of failure is reached. Therefore, the reliability of a component subjected to a cyclic load with constant amplitude can be calculated by considering S/N curves at different reliability values and combining the number of cycles which are required at the considered constant amplitude to reach the S/N curve.

The load rating capacity of a single gear tooth is typically calculated for its pitting resistance, bending strength, scuffing resistance, micropitting resistance and static strength [3, 12]. Pitting strength relates to the Hertzian contact (compressive) stresses located on the tooth flank, while bending strength is measured in terms of the bending (tensile) strength in a cantilever plate located in the tooth root. The additional most common failure modes are micropitting, wear and scuffing which are mainly affected by the lubrication.

Imposed by ISO 81400-4:2005 [4], it is required to perform the standard rating for pitting resistance and bending strength in a WT gearbox application. This results in two different allowable limits of contact and bending stress rating numbers for identical materials and load intensities. The stress amplitudes for both the contact and bending stress cycles are primarily affected by the transmitted torque. The rotational speed is required to calculate the number of stress cycles. Using a dedicated S/N curve for both bending strength and pitting resistance the reliability can be calculated.

With respect to reliability predictions of gears it can be assumed that the probability that one gear will not fail (defined by the gear reliability  $R_{gear}(t)$ ) is the product of the probabilities that none of the gear teeth will fail due to pitting ( $R_{pitting}(t)$ ) and bending fatigue ( $R_{bending}(t)$ ) and the probability that the lubrication will not lead to gear surface distress failure modes such as micropitting, wear and/or scuffing ( $R_{surface\ distress}(t)$ ). Under the assumption that the gear is properly designed such that overloading will not occur, assembled with care such that no additional misalignment loads occur and properly maintained, the reliability model of a gear may be given by:

$$R_{gear}(t) = \left(R_{pitting}(t)\right)^Z \left(R_{bending}(t)\right)^Z R_{surface\ distress}(t) R_{random}(t) \quad (3)$$

where  $Z$  is the number of teeth. The reliability  $R_{random}(t)$  is added to incorporate the probability

that the assumptions made are not valid. This reliability can be modeled as an exponential distribution with a constant failure rate since failures due to errors in the assumptions can be assumed random over time, which may include overloading due to excessive wind or mechanical failures of the brake, assembly error, neglecting to replace the oil, lightning impact, etc.

To determine the reliability curves for  $R_{pitting}(t)$ ,  $R_{bending}(t)$ ,  $R_{surface\ distress}(t)$  and  $R_{random}(t)$ , field failure data can be analyzed using Weibull analysis by distinguishing the gear failures between pitting fatigue failures, bending fatigue failures, surface distress failures and all other failures. If no field data is available, the curves must be calculated. For this the standards ANSI/AGMA 2001 or ISO 6336 (for  $R_{pitting}(t)$  and  $R_{bending}(t)$ ) and AGMA 925 – A03 (for  $R_{surface\ distress}(t)$ ) can be used. The  $R_{random}(t)$  can be seen as the "tuning" parameter to adjust the total gear reliability to be consistent with in-house experience.

The above outlined procedure for gear reliability prediction can be transferred to other critical components, such as bearings and shafts, in a WT gearbox. Using the developed advanced reliability analysis method, more realistic prediction for a WT gearbox may be possible.

## 5 Conclusions

This paper presented a generic approach to model a WT gearbox for the reliability prediction. A modular structure and definition has been developed including all critical components affecting the gearbox reliability. The failure rates of critical components in a gearbox have been estimated by using the formulae and associated data available from NSWC07. Using Relex software, the failure rates of three generic gearbox configurations have been predicted to assess the effects of different designs on the overall performance of wind turbines. The advanced reliability analysis model outlined may be used to improve the reliability prediction of a gearbox by applying more realistic field failure data if they would become available in the future.

The research has highlighted that field failure data collection and exchange between end-users, WT manufacturers, gearbox manufacturers and bearing manufacturers is essential to estimate the

true reliability, to determine and/or to validate reliability models, and to improve the overall reliability and thus increase WT availability.

## Acknowledgement:

This work was funded by the EU FP7 Project RELIAWIND 212966. The authors would like to thank RELIAWIND project partners for useful discussions and suggestions.

## References:

- [1]. EWEA. The Economics of Wind Energy. March 2009.
- [2]. F. Spinato, P.J. Tavner, G.J.W. van Bussel, and E. Koutoulakos. Reliability of wind turbine subassemblies. IET Renewable Power Generation, Vol. 3, Issue 4, pp1-15, 2009.
- [3]. ANSI/AGMA 2001-D04. American Gear Manufacturers Association – Fundamental Rating Factors and Calculation Methods for Involute Spur and Helical Gear Teeth. 2001.
- [4]. IEC 61400-4 (ISO 81400-4: 2005 (E)). Wind Turbines - Part 4: Design and Specification of Gearboxes, first edition, 2005.
- [5]. W Musial, S Butterfield, B. and McNiff. Improving Wind Turbine Gearbox Reliability. The 2007 EWEC Conference, Italy, May 2007.
- [6]. Kris Smolders. Reliability Analysis of Gearbox. RELIAWIND Project Report – Task 2.4. June 2009.
- [7]. Relex Reliability Analysis Software (<http://www.relex.com/products/index.asp>).
- [8]. VGB PowerTech. Guideline: Reference Designation System for Power Plants RDS-PP – Application Explanations for Wind Power Plant (VGB-B 116 D2), first edition, 2007.
- [9]. RELIAWIND Wind Turbine Generator Classification. Internal Report, November 2008.
- [10]. Sandia – Wind Plant Taxonomy v1.1. US Wind Turbine Reliability Workshop, June 2009.
- [11]. NSWC07 Handbook of Reliability Prediction Procedures for Mechanical Equipment. 2007.
- [12]. AGMA 925 – A03, Effect of Lubrication on Gear Surface Distress.