



Wind Turbine SCADA Alarm Analysis

Dr. Yingning Qiu

Energy Group , New & Renewable Energy Subgroup
Durham University

SCADA Alarms

- Direct operator's attention towards plant condition;
- To ensure timely assessment and action;
- SCADA alarms have lower storage requirements than SCADA or CMS signals;
- But alarms are noisy;
- And alarms have complex patterns

Alarm System Performance Evaluation KPIs

- **KPIs: Key Performance Indices***
 - Average Alarm Rate: long term average number of alarms /10 min
 - Maximum Alarm Rate: maximum number of alarms /10 min
 - Percentage time an alarm's rate is within a pre-defined number range
- **Additional Definitions**
 - Alarm Shower: A single fault can cause a large number of alarms which are above 10

* Alarm systems, a guide to design, management and procurement No. 191
Engineering Equipment and Materials Users Association 1999 ISBN 0 8593
1026 0

Alarm KPIs of 7 Wind Farms

Alarm KPIs		Geared Drive, Variable Speed, 1.67 MW WTs						Geared Drive, Fixed Speed, 1.0 MW WTs
		Wind Farm1	Wind Farm2	Wind Farm3	Wind Farm4	Wind Farm5	Wind Farm6	Wind Farm7
Total WT Numbers		13	15	31	30	30	34	153
KPI1: Average Alarm Rate Per 10 mins	Per Wind Farm	4	8	11	10	10	21	10
	Per Wind Turbine	0.34	0.50	0.37	0.35	0.32	0.61	0.07
KPI 2: Maximum Alarm Rate per 10 mins	Per Wind Farm	391	1143	636	1570	439	541	289
	Per Wind Turbine	30.1	76.2	20.5	52.3	14.6	15.9	1.9
KPI 3: Percentage of Time Alarm Rates are within these ranges per Wind Farm	0	57	33	24	19	20	7	1
	1 to10	28	44	47	50	48	34	64
	11 to 50	14	21	27	30	31	54	35
	>50	1	2	2	1	1	5	0
	In Total	100	100	100	100	100	100	100

Alarm System Performance Levels

Matrix for Alarm System Performance Evaluation*

- **Reactive**- peak alarm rate during upset is unmanageable and alarm system will continue to present an unhelpful distraction to the operator for long period.
- **Stable**- alarms have been well defined for normal operation, but the system is less useful during plant upset.

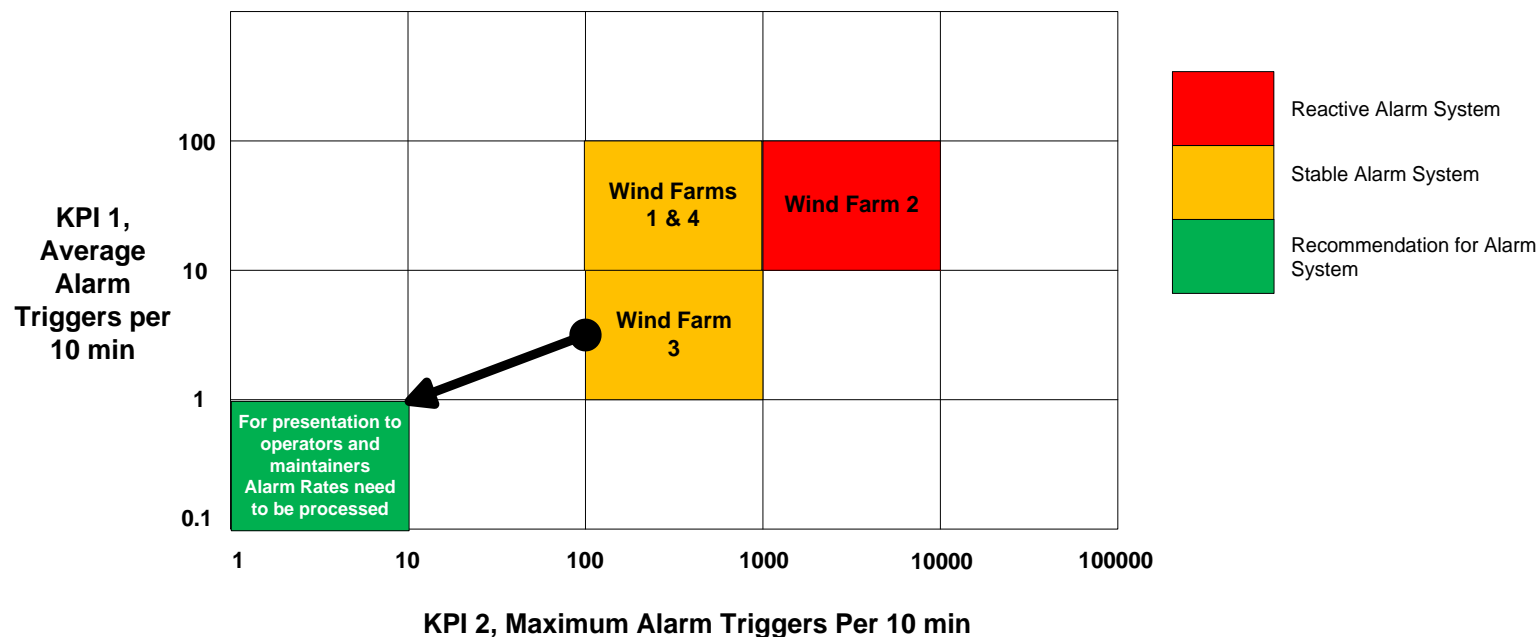

Warning!

The 1994 explosion and fires at the Texaco Milford Haven refinery injured twenty-six people and caused damage of around £48 million and significant production loss. Key factors that emerged from the Health and Safety Executive's (HSE's) investigation¹ were:

- There were too many alarms and they were poorly prioritised.
- The control room displays did not help the operators to understand what was happening.
- There had been inadequate training for dealing with a stressful and sustained plant upset.

In the last 11 minutes before the explosion the two operators had to recognise, acknowledge and act on 275 alarms.

Scary ! Is this possible In Wind Energy? Yes!

- High alarm rates reduce the operator's sensitivity to failure with catastrophic consequences.
- High alarm rates increase WT downtime and reduce WT availability
- We must deal with alarms from offshore WTs
- WT alarms installation should accord with health and safety regulations

Wind Turbine Alarm System Configurations

Alarm function →

Alarm location ↓

	General Warning	System Operation Monitoring	Environment Monitoring	Comms/ Conn/ Software
Maintenance Activity	√			
Pitch System and Blade/Rotor	√	√		√
Gearbox	√	√		√
Generator	√	√		√
Converter	√	√		
Transformer	√	√		
Grid Situation			√	
Hydraulic System	√	√		
Yaw	√	√		√
Connection and Control Unit	√			√
Environment			√	
Others	√	√	√	

Wind Turbine Alarm Configuration

The Ratio of Alarms in Each Category to the Total Numbers of Alarms of a WT

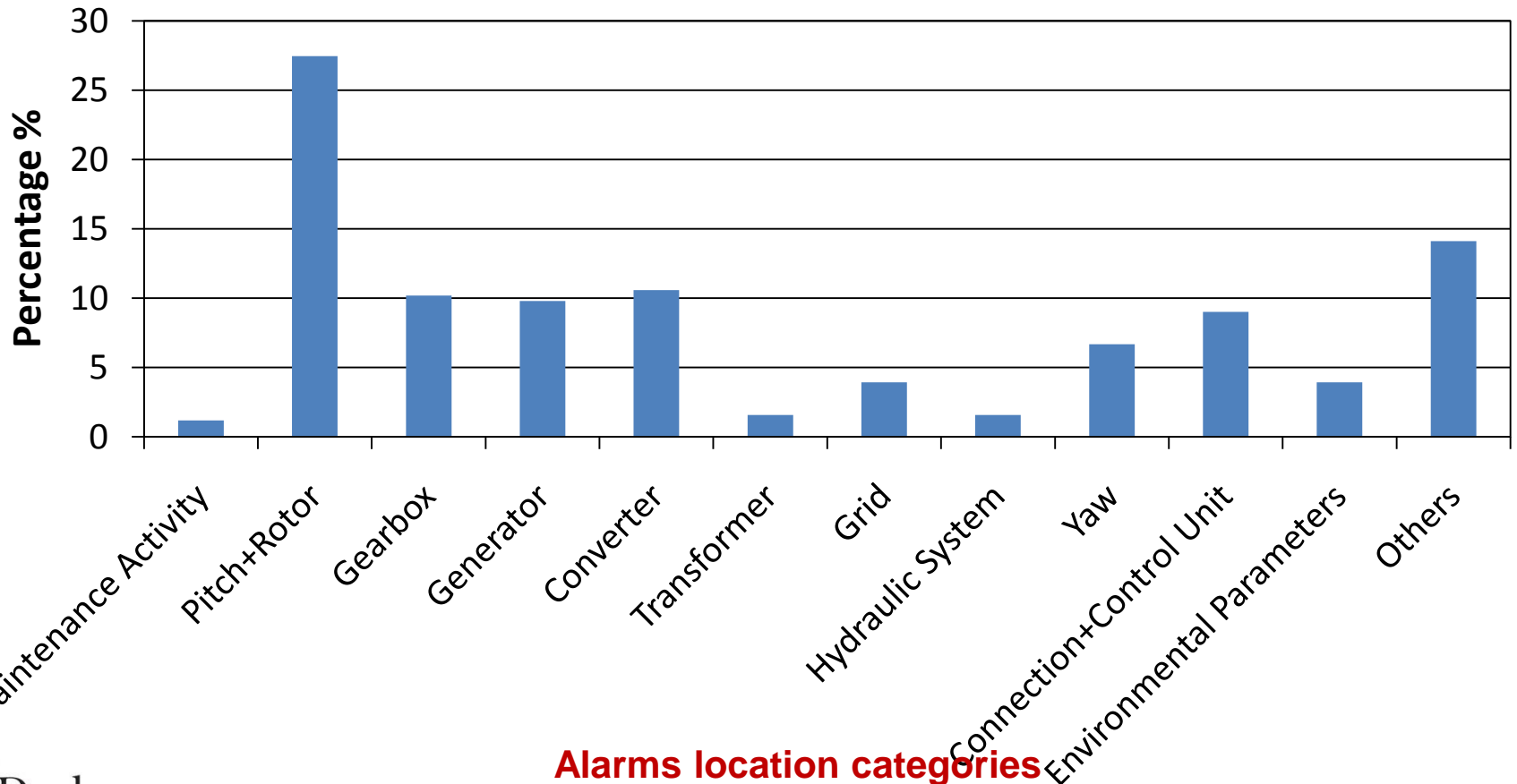

Alarm Shower Investigation

Distribution of Alarms in Different Alarm Ranges

1-10

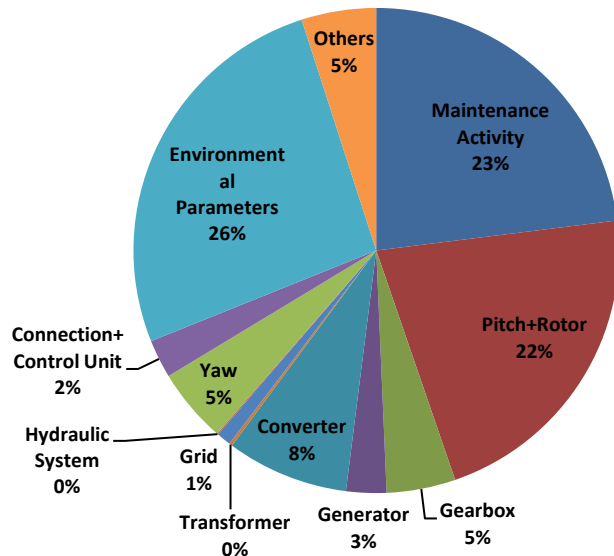

11-50

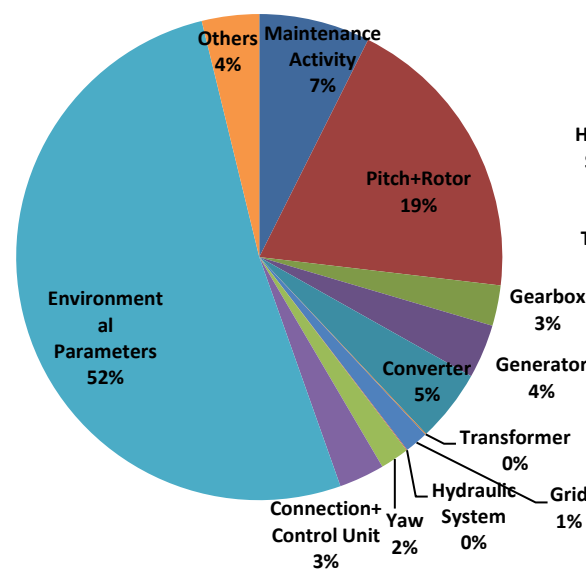

>51

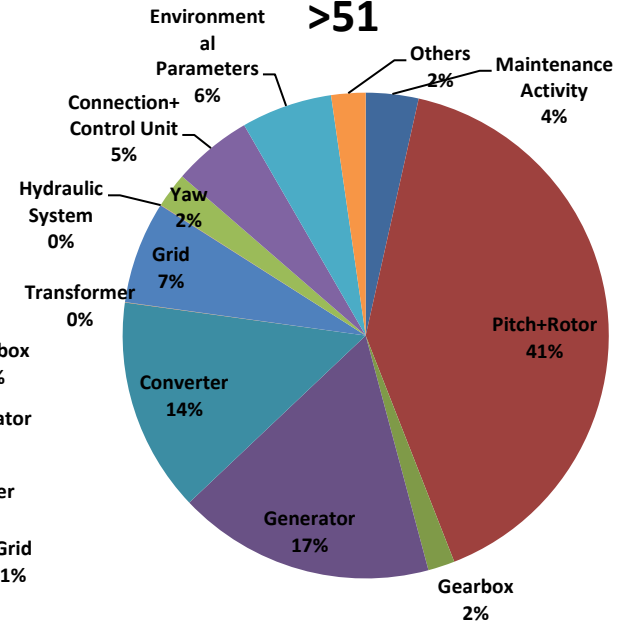

Alarm Shower Investigation

- High proportion of **pitch/rotor, generator & grid /converter alarms** with high alarm rates -need to optimise pitch/rotor alarms and improve WT tolerance to grid faults.
- Low proportion of **gearbox, transformer, yaw & hydraulic alarms** in all alarm rates- intrinsic difference between mechanical and electrical Failure mechanisms.
- Decreasing proportions of **maintenance, yaw and environmental alarms** in high alarm rates - showing random occurrence of these events and low subsequent effect on WT.
- Within alarm rate range of 11-50 /10 min, over half alarms due to the environmental events. However, cumulative damage is still possible.

Alarm Shower Further Investigation

- Normalized Cumulative Alarm Duration vs Calendar Time
- 10 alarms which are associated with grid fault are chosen

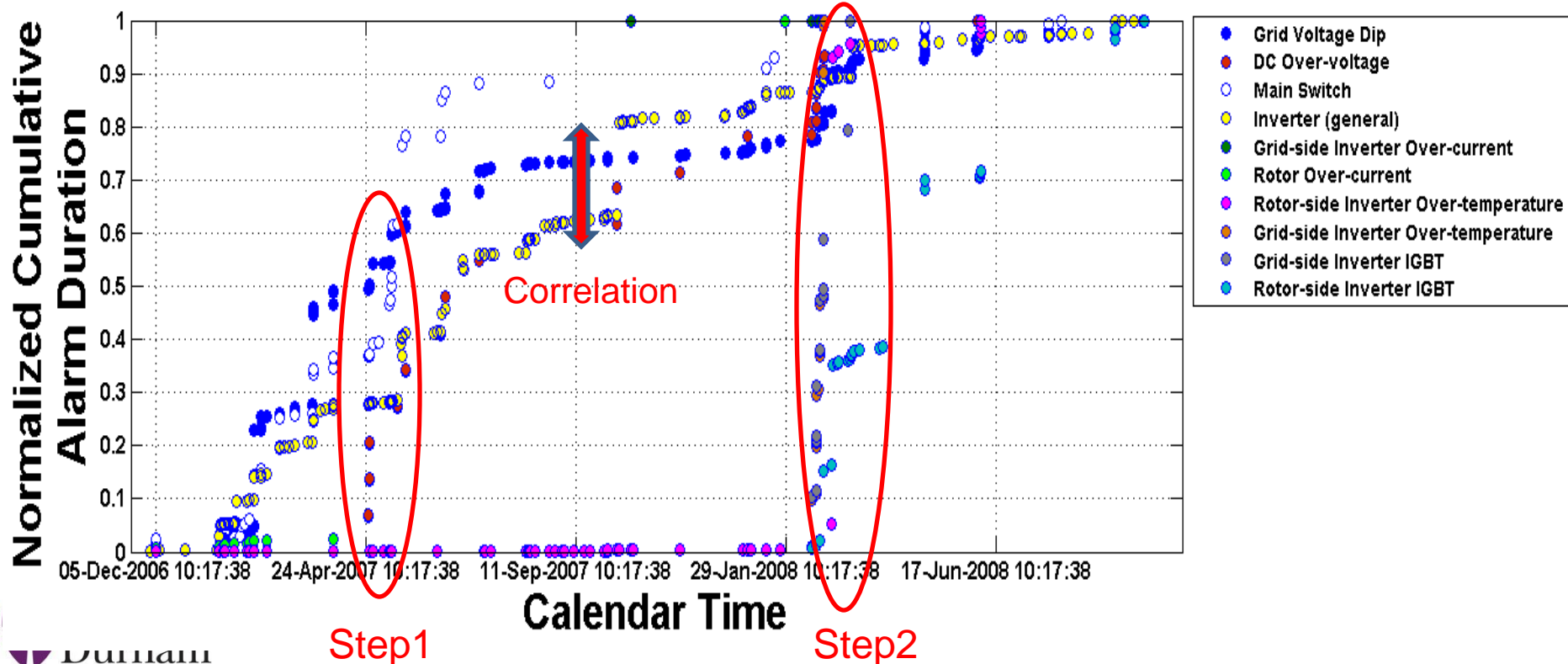

Alarm Shower Further Investigation



- Grid Voltage Dips caused >10 Generator & Converter alarms.
- 15-20 alarm triggers observed on each WT at each Dip
- For a WF with 15-30 WT \equiv 200-600 alarms indicating an alarm rate >1000 per 10 min.
- Converter alarms strongly correlate to Grid Voltage Dip indicating root cause.
- Steps in alarm curve indicate frequent triggers with long duration.
- Steps always accompanied by Converter component Failures, e.g IGBT.
- Suggests possible use of steps to study cumulative stress effects.
- Pitch system also responded, indicating operation of WT EFC alarm.
- Need to improve WT alarm design to deal with Grid Voltage Dip.

WT alarm & WT Risk and Reliability

- WT alarms provide comprehensive information on WT running state.
- WT alarms present Failure event sequence and probability
- Helps to construct fault trees for the complex WT electro-mechanical sub-systems.
- Helps to understand whole system functional logic with a low storage requirement
- Reveals potential catastrophic Failure at WT systematic level.
- Is a powerful tool to perform WT risk, safety and reliability assessment.

Complex Alarm Processing Methods

1. Time-Sequence Analysis

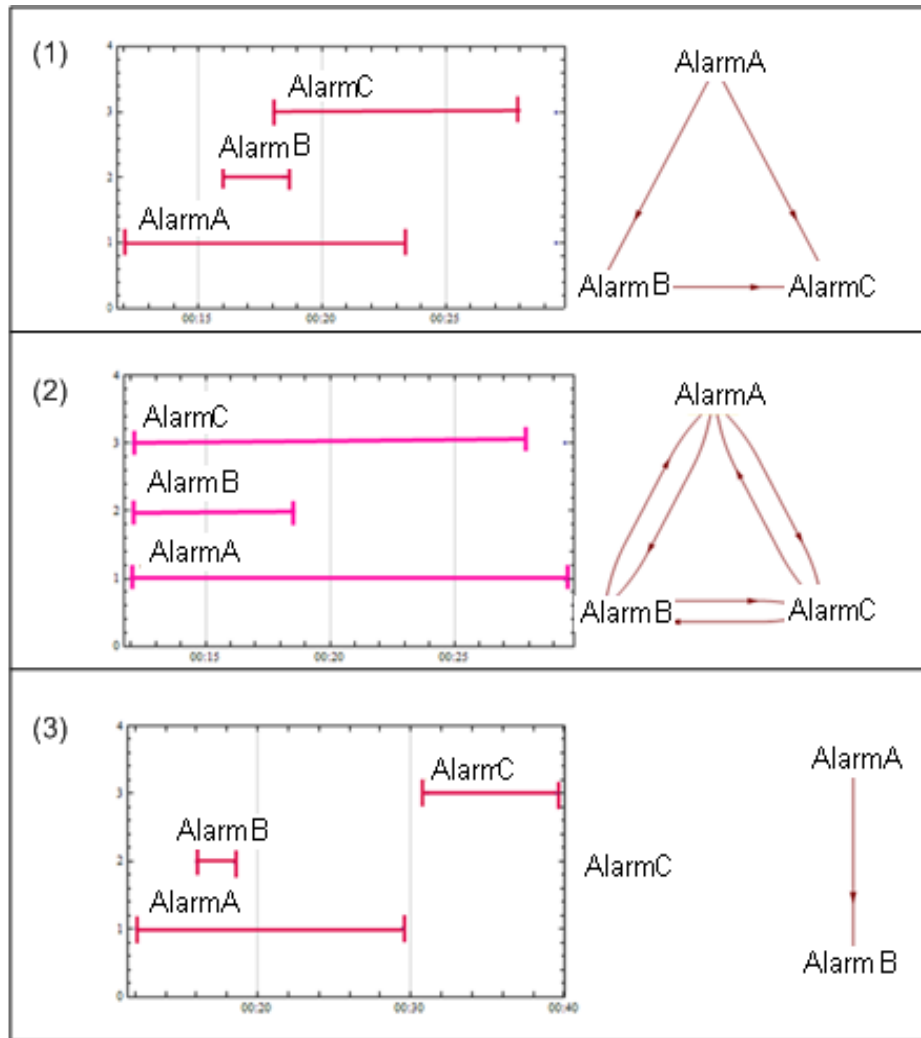

- $t_{sA} < t_{sB}$ and $t_{eA} > t_{sB} \rightarrow$
 $A \rightarrow B$: AlarmA triggers Alarm B
- $t_{sA} = t_{sB} \rightarrow$
 $A \leftrightarrow B$: AlarmA and AlarmB triggers each other
- $t_{eA} < t_{sC}$ or $t_{sA} > t_{eC} \rightarrow$
 AlarmA and AlarmC are independent to each other
- t_{sX} : alarm X start time
- t_{eX} : alarm X end time

2. Probability-Based Analysis

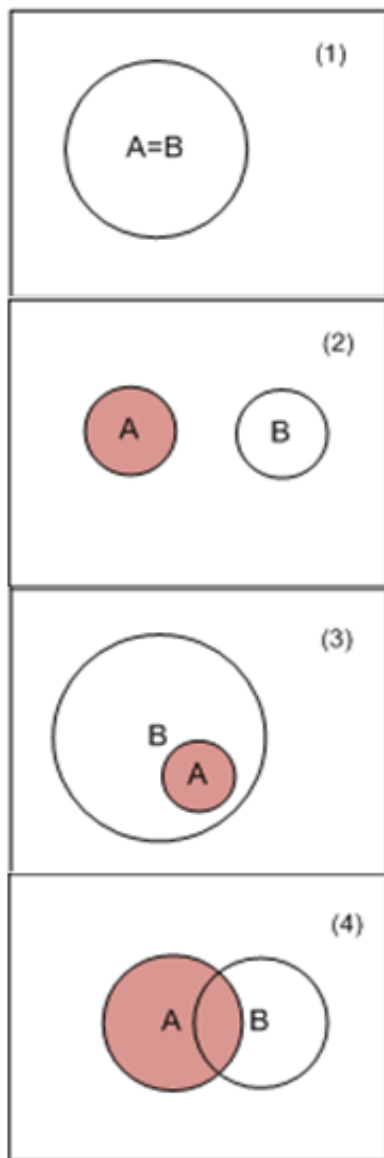

(1) $P(B|A) \approx 1$ and $P(A|B) \approx 1$ $\rightarrow A = B$

It presents two closely related alarms (A and B) which always appear together.

(2) $P(B|A) \approx 0$ and $P(A|B) \approx 0$ $\rightarrow A \cap B = 0$

It presents two independent or weakly related alarms (A and B) which never appear together

(3) $P(B|A) \approx 1$ and $P(A|B) \neq 1$ $\rightarrow A \in B$

It can be interpreted as alarm B will be triggered whenever alarm A appears.

(4) $P(A|B) \neq 1$ and $P(B|A) \neq 1$ $\rightarrow A \cap B \neq 0$

It presents a case that two alarms randomly related.

Results – Converter Failure

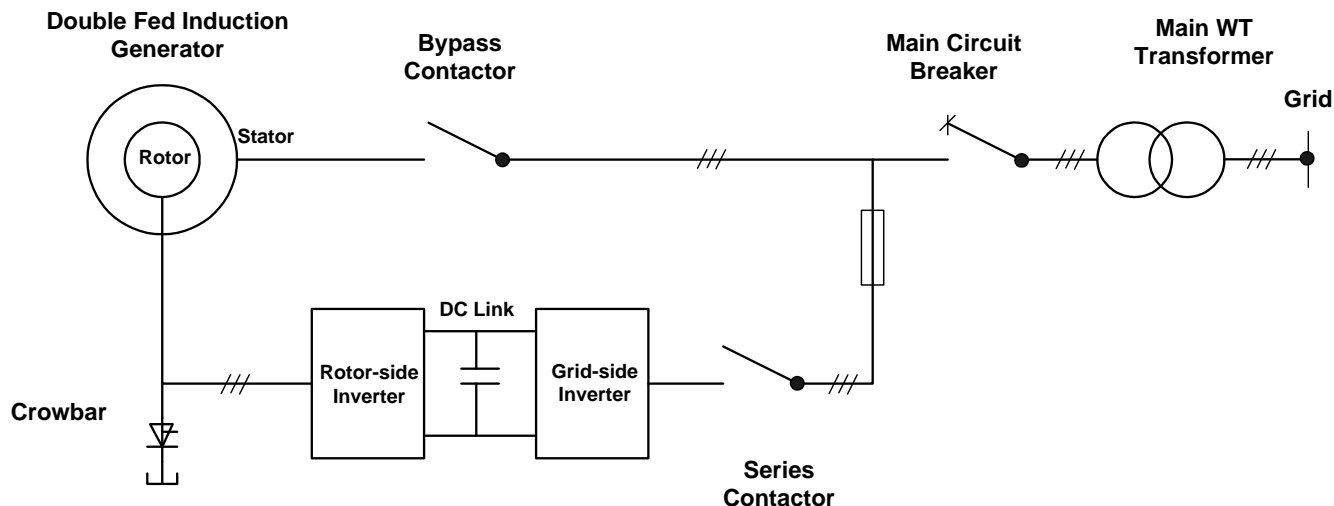

Alarm Name
Inverter (General)
Rotor Over-current
Rotor-side Inverter Over-temperature
Grid-side Inverter Over-current
Grid-side Inverter Over-temperature
Grid Voltage Dip
DC Over-Voltage
Main Switch
Pitch
Blade1-3 Emergency

Time Sequence Analysis Result

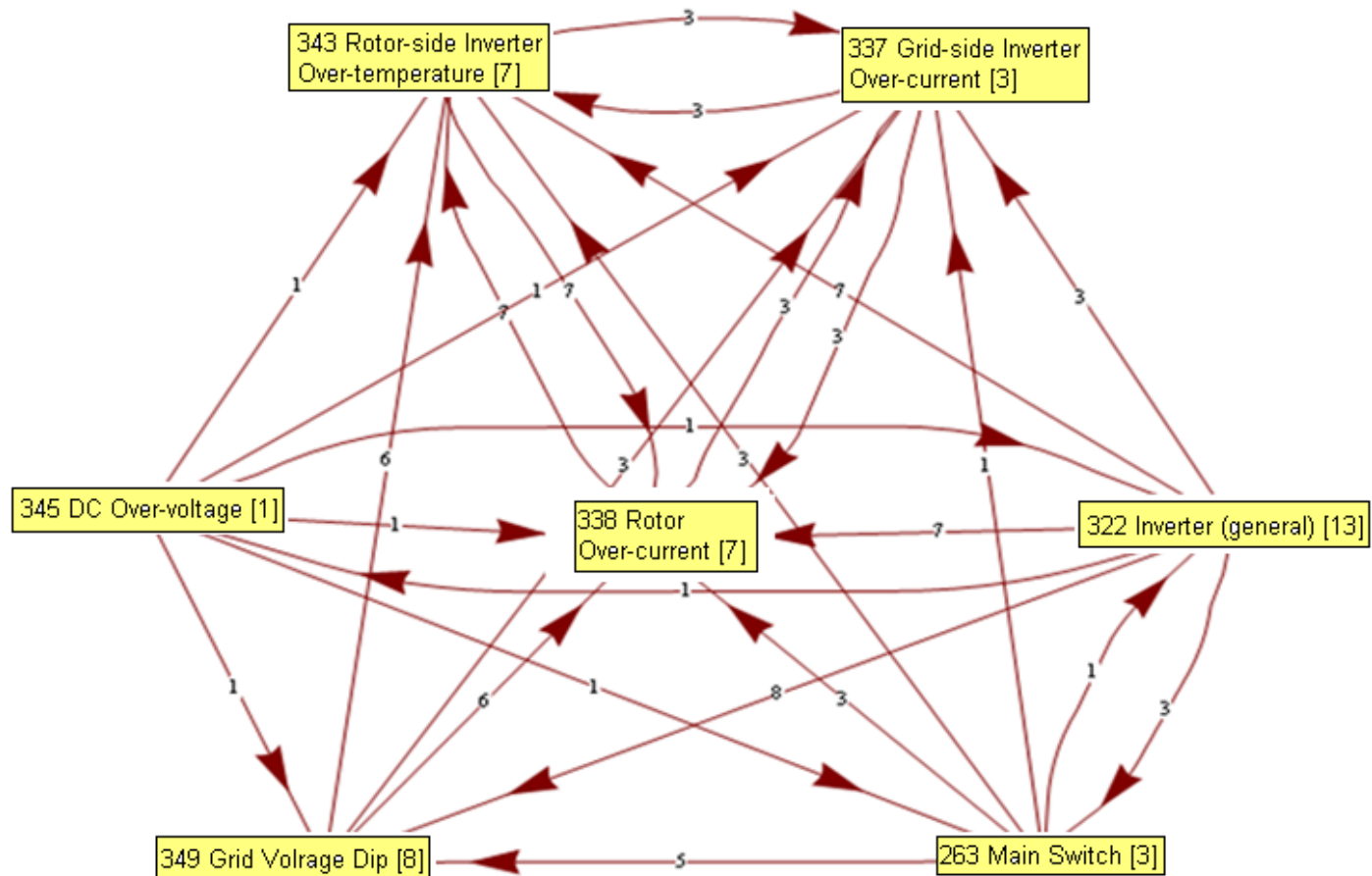

Probability Analysis Result

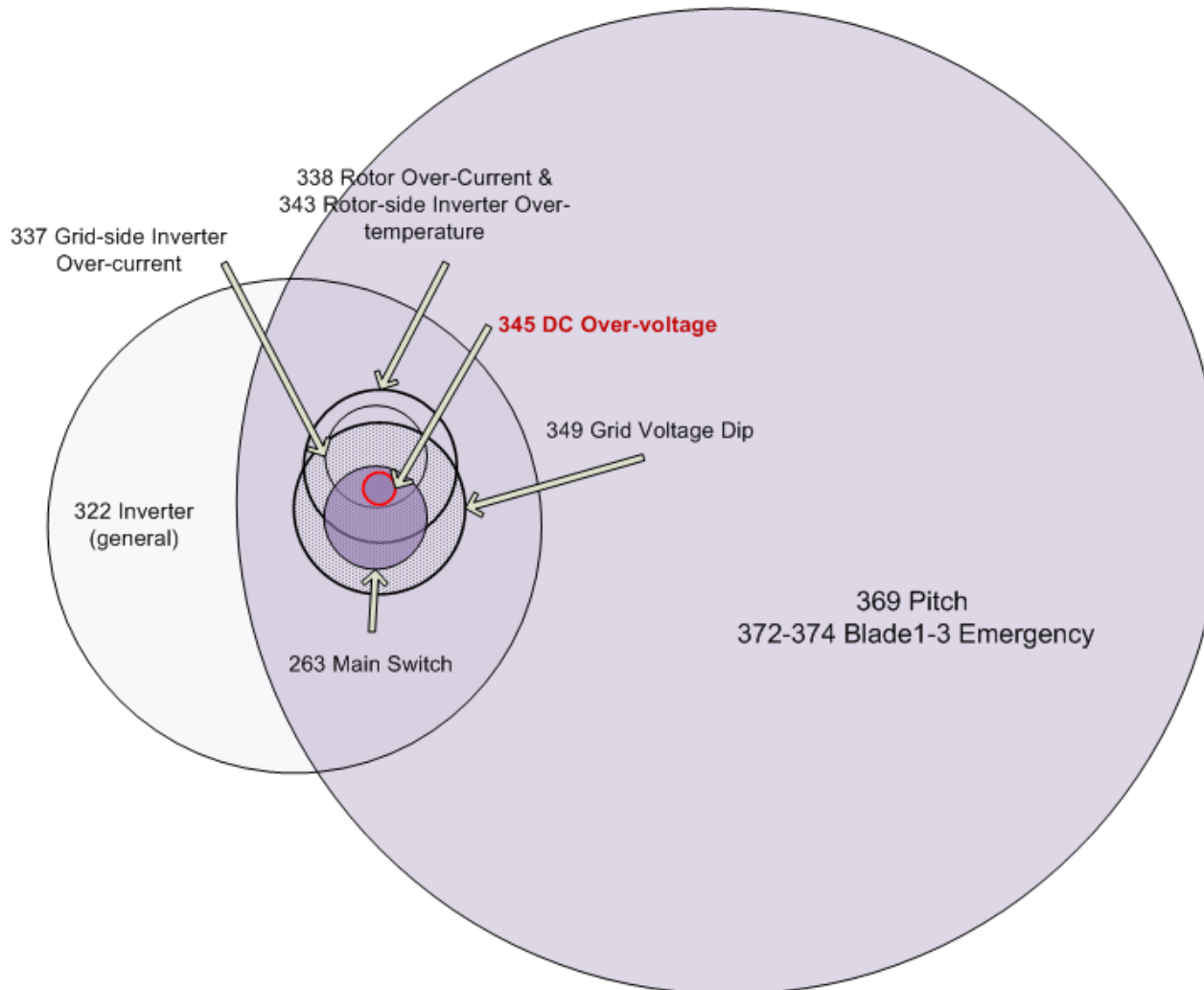

Converter Failure Analysis

- Grid Voltage Dip → Rotor Over-current and Rotor-side Inverter Over-temperature → DC Over-voltage → Grid-side Inverter Over-current → Pitch Emergency Feather Control
- The accuracy of the alarm time sequence relies on the Failure mechanism and a high sampling rate data collection system
- The probability- based method relies on a relatively large amount of historical data
- The complex pattern is due to the complex of control logic and various grid voltage dip range

Results – Pitch Motor Failure

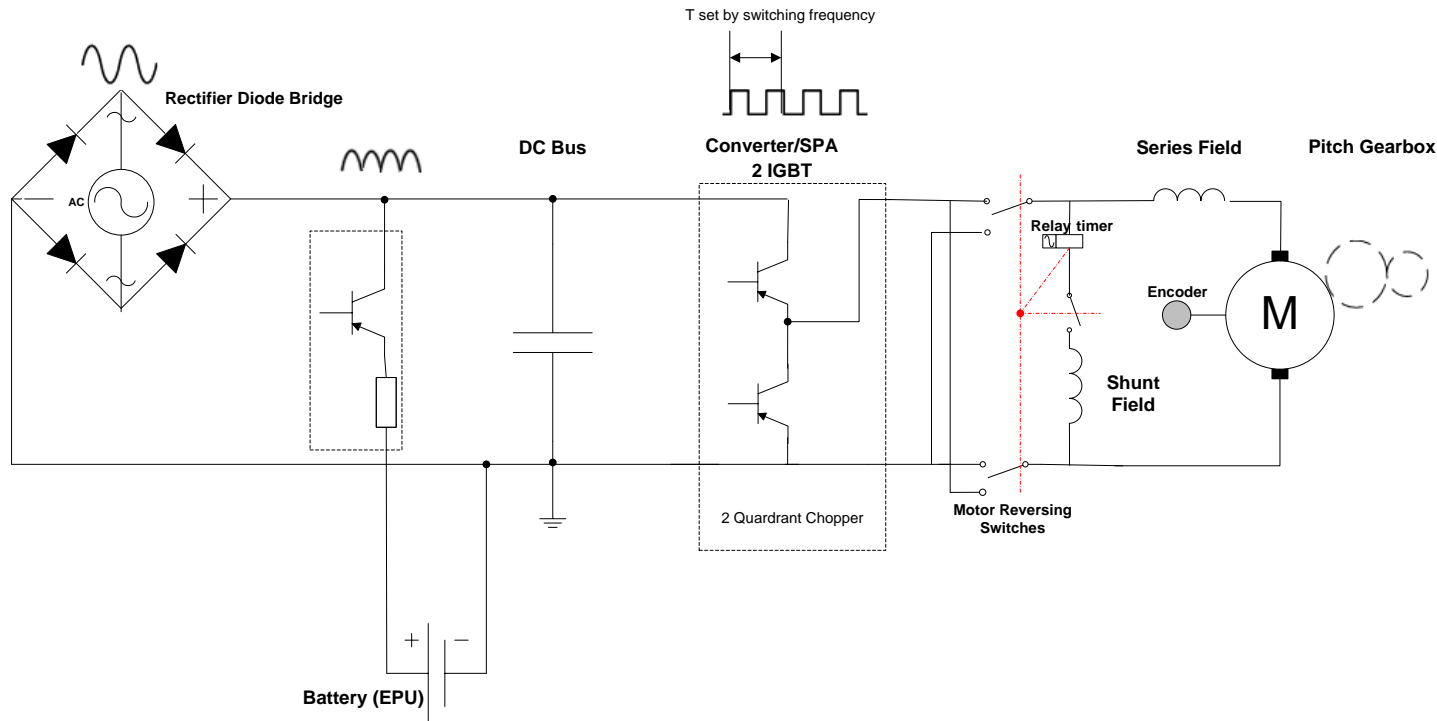

Alarm Name

Pitch

Blade1-3 Emergency

Warning Pitch (general)

PCP Initiated Emergency Feather Control

Blade 1 Saturation Limit

Blade 1 Short Circuit

Servo Pitch Amplifier (SPA) Fault Blade 1

Time Sequence Analysis Result

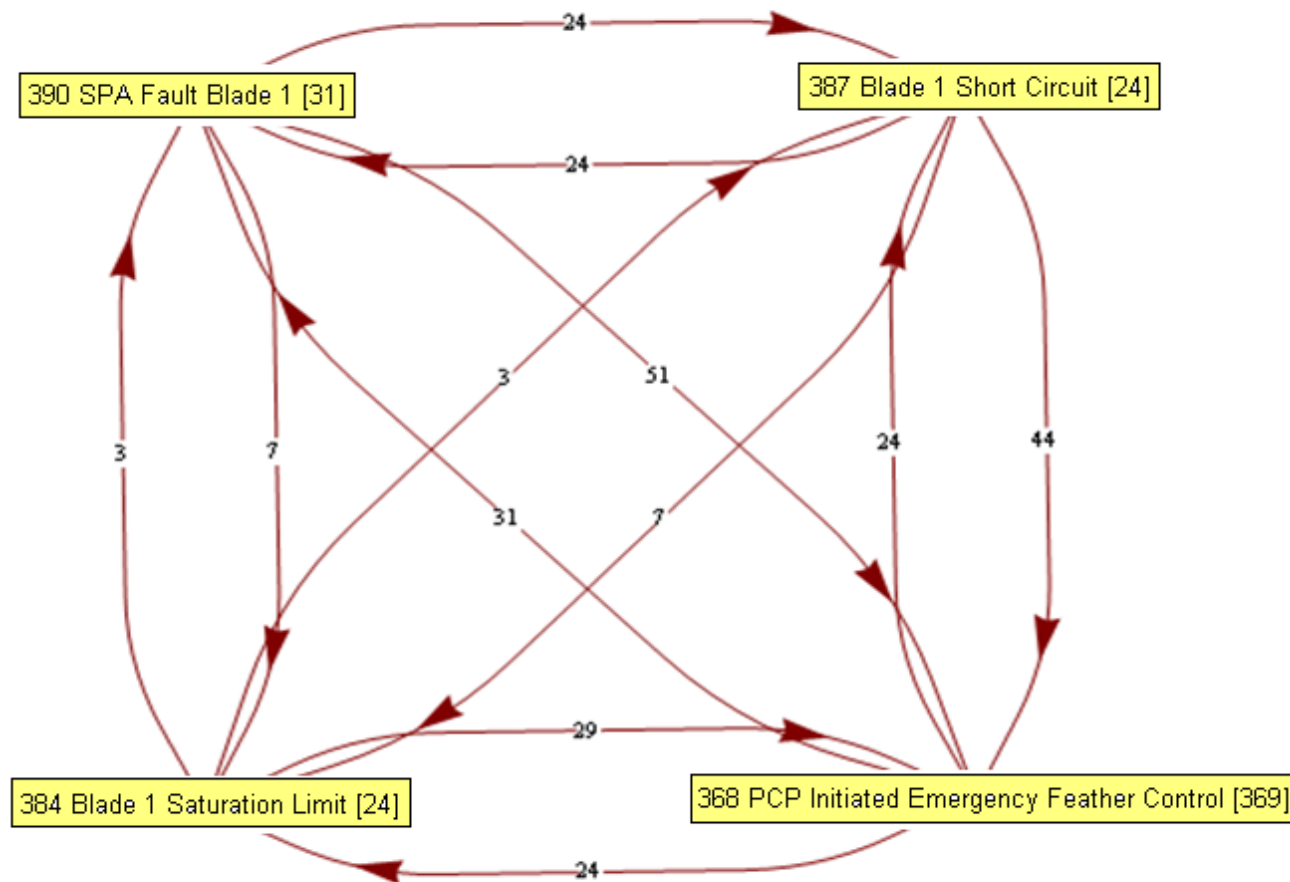

Probability Analysis Result

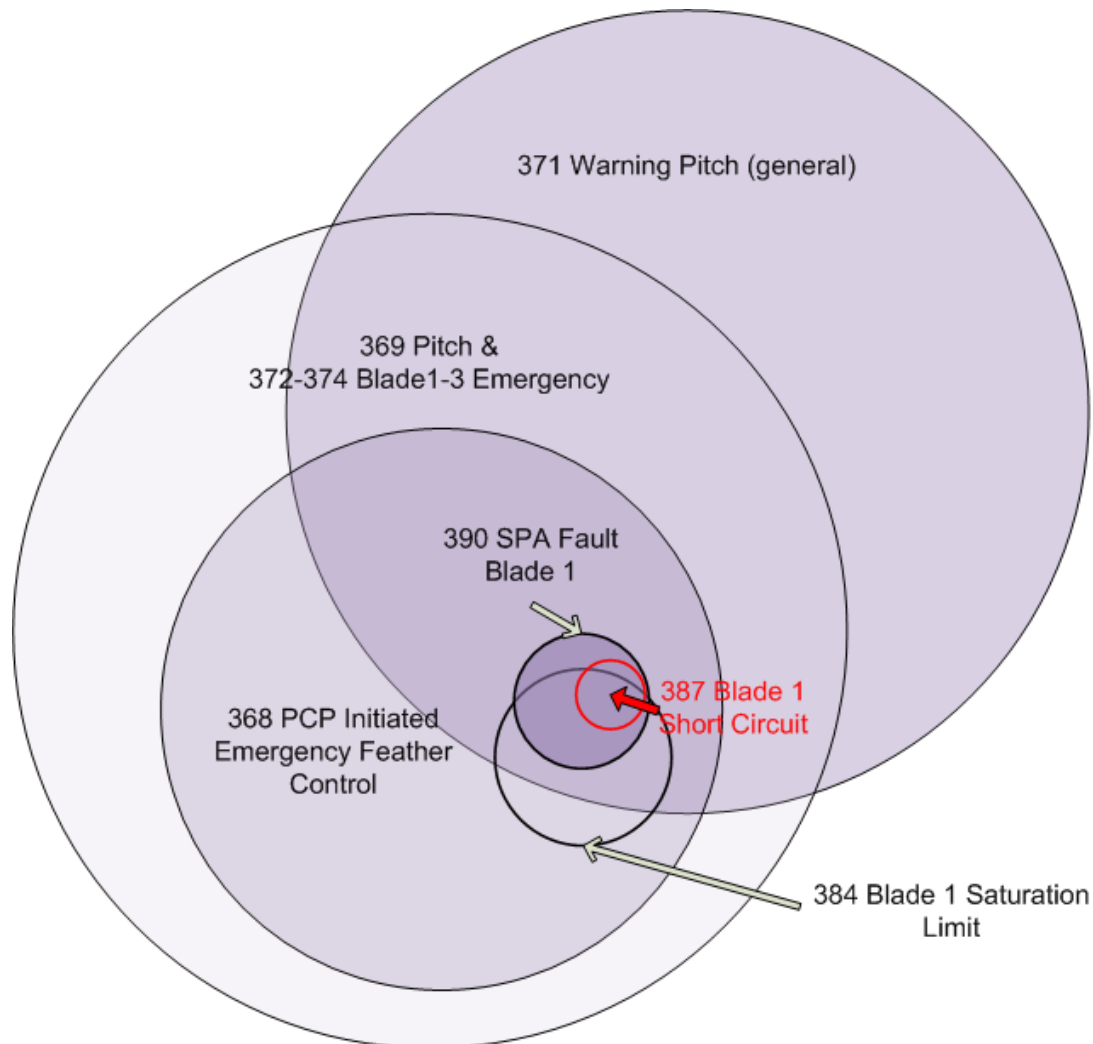

Pitch Motor Failure Analysis

- Blade 1 short circuit → Servo Pitch Amplifier (SPA) Fault
Blade 1 → Blade 1 Saturation Limit → PCP initiated EFCs
→ Blade Emergency Reactions
- Time sequence does not show root cause
- Venn Diagram clearly shows the root cause

Time-Sequence vs Probability-Based Analysis

	Time Sequence Analysis	Probability Analysis
Advantages	Simple and rapid, can be applied for on-line analysis	Weakens timing effects
	Shows fault linkages	Shows Failure root cause
		Show potential Failure events path
		Simple data storage system required
Disadvantages	Root cause alarm may not be the first	Venn Diagram quality needs to be improved and it need to be automated
	It is determined by Failure mechanism	Require long term of historical data
	Accuracy relies on a high sampling rate data collection system	Its pattern is affected by control logic
	Alarm duration affects the result	

Value of SCADA Alarm Analysis

- Avoids risk of severe WT damage
- Enables WT reliability improvement
- Standard to regulate WT alarm installation and management is urgently needed;
- Such a standard exists in Oil & Gas and should be adapted to WT application
- Converter and Pitch alarm triggers were in the forefront of 519 WTs studied in this paper.
- Alarms provide valuable information to identify Failure locations and root causes while requiring lowest storage and analysis costs.
- Time-sequence analysis is simple compared to probability-based analysis giving root cause but requires significant time of data analysis.
- These issues need to be resolved in a larger study, likely that a combination of two methods will be required.
- Event-oriented, probability-based analysis on WT alarms shows the potential for linkage with an FMEA of the WT.



Thank You!

Yingning.qiu@durham.ac.uk