

Induction Generator Condition Monitoring Based in Stator Current Analysis

Damian S. Vilchis-Rodriguez
University of Manchester
School of Electrical & Electronic Engineering
Power Conversion Group

Supergen Wind Training
Loughborough
12-13th September 2011

Definitions

- **Condition monitoring**
Collection and Interpretation of data suitable for a quantitative assessment of equipment and component condition for the purpose of instituting and conducting condition-based, predictive maintenance programs.
- **Current signature analysis**
Is a non-invasive technique used to determine the operating condition of AC rotating machinery. CSA techniques can be used in conjunction with vibration and thermal analysis to confirm key machinery diagnostic decisions. CSA operates on the principle that induction machine circuits can, in essence, be viewed as a transducer and harmonic fluxes are produced in the air gap. These fluxes induce current components in the stator winding that produce current components at predictable frequencies.
- **Closed frequency expressions**
Analytical expressions that relate the frequencies in the current spectrum with the operational condition of the machine.

General rules for DFIG steady state stator current harmonic frequencies for various balanced/unbalanced operating conditions

WINDINGS		SUPPLY		INDUCED DFIG STATOR CURRENT FREQUENCIES
STATOR	ROTOR	STATOR	ROTOR	
BALANCED	BALANCED	BALANCED	BALANCED	$f_{ind}^k = 6k(1-s) \pm 1 f$
BALANCED	BALANCED	BALANCED	UNBALANCED	$f_{ind}^k = 6k(1-s) \pm 1 f$ $f_{ind}^k = 6k(1-s) \pm (1-2s) f$
BALANCED	UNBALANCED	BALANCED	BALANCED	$f_{ind}^k = \left \frac{2k}{p}(1-s) \pm \left[s + \frac{1-s}{p} \right] \right f$
BALANCED	BALANCED	UNBALANCED	BALANCED	$f_{ind}^k = 6k(1-s) \pm 1 f$
UNBALANCED	BALANCED	BALANCED	BALANCED	$f_{ind}^k = \left \frac{2k}{p}(1-s) \pm 1 \right f$

$$k=0, 1, 2, 3 \dots$$

Steady-state analysis: Frequency content of predicted and measured stator line current for healthy DFIG and a stator winding open-circuit fault

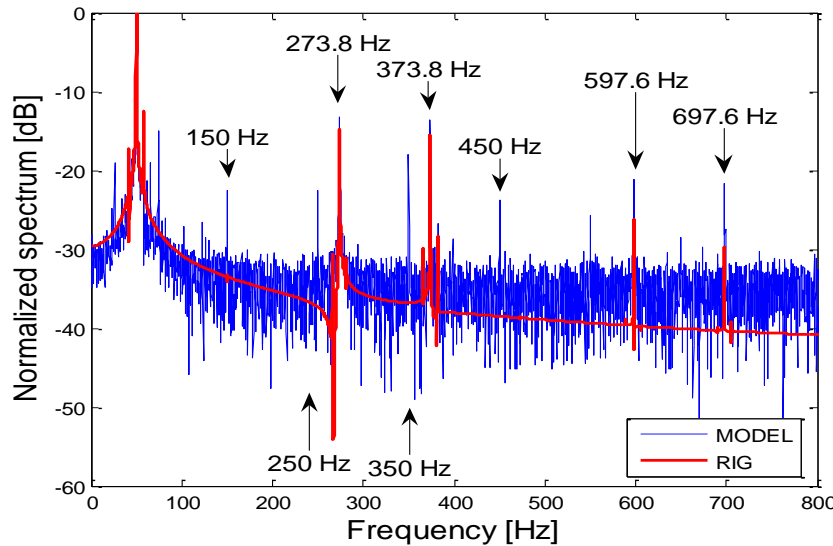

a) Healthy DFIG

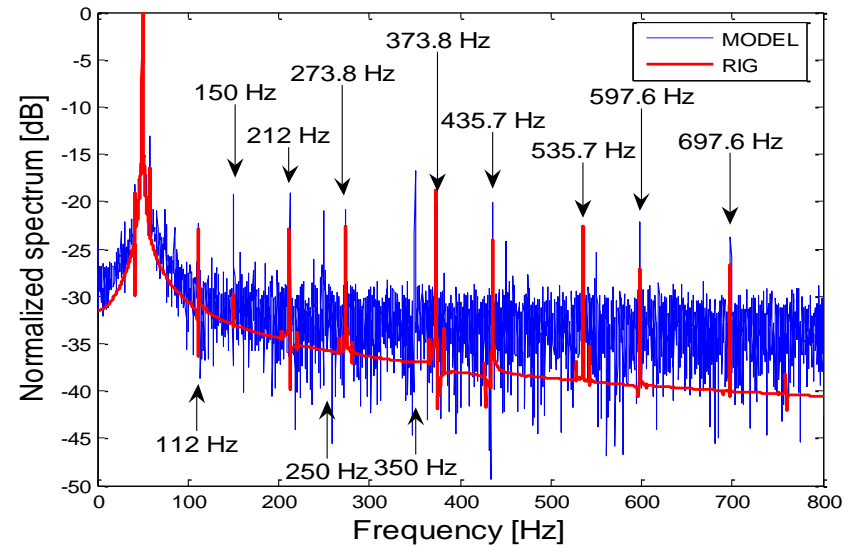

b) Stator winding fault

Steady state analysis: Predicted and measured DFIG stator line current spectra DFIG operating on-line with winding fault

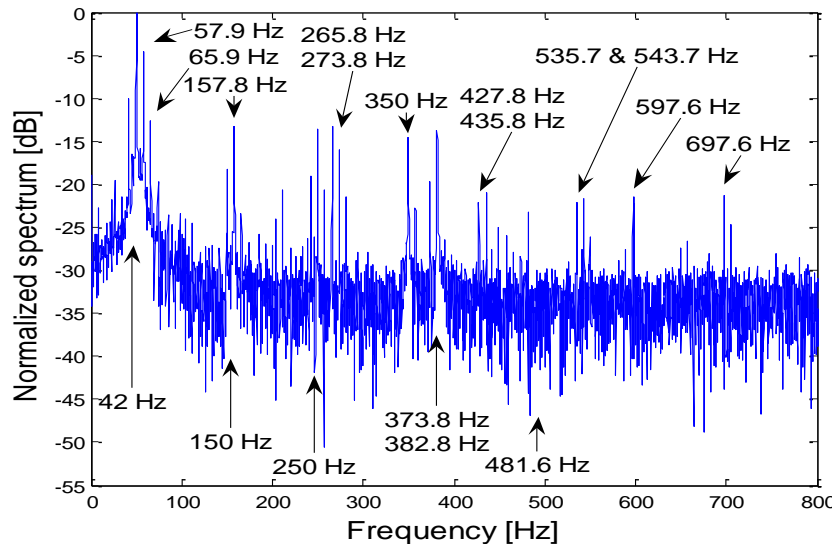

a) Experimental current spectrum

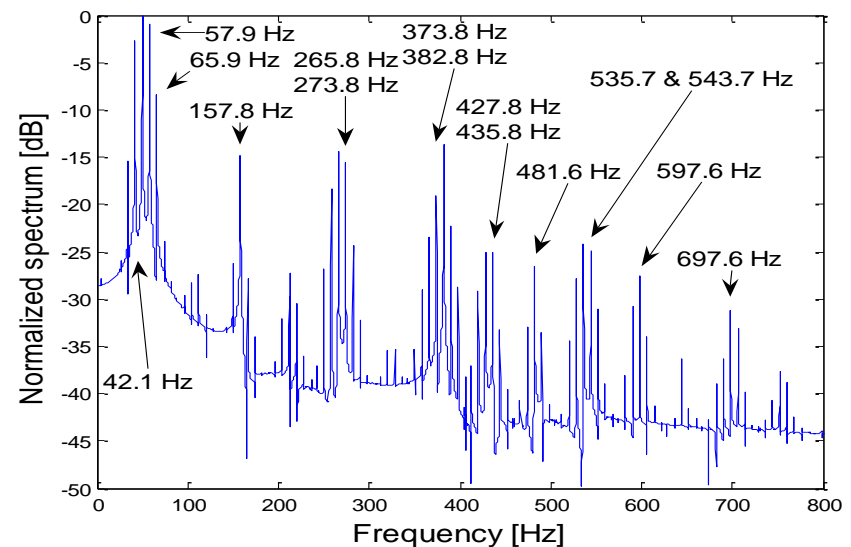

b) Predicted current spectrum

DFIG operation with rotor winding fault

Bearing faults

- Account for 40 % of machine failures
- Vibration analysis is the preferred method for mechanical faults detection
- A fault induces the appearance of a characteristic frequency in the vibration spectrum

Why to use CSA ?

- Current transducer are cheaper than vibration transducer
- Uses existent infrastructure, stator current is usually measured
- Less susceptible to external vibration
- Reliability improvement in fault detection by using redundant detection mechanisms

Rolling bearing parts

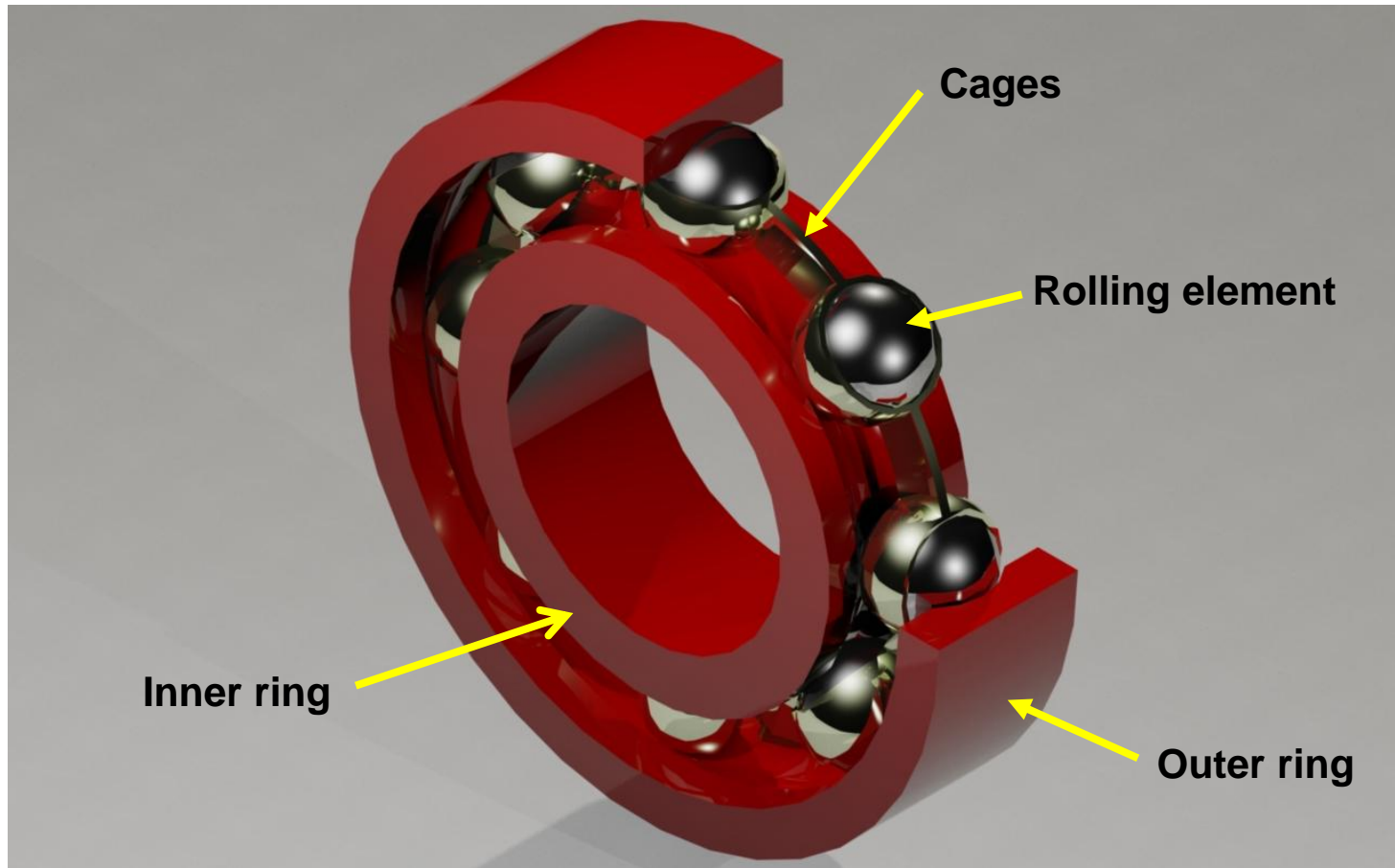

Rolling bearing geometry

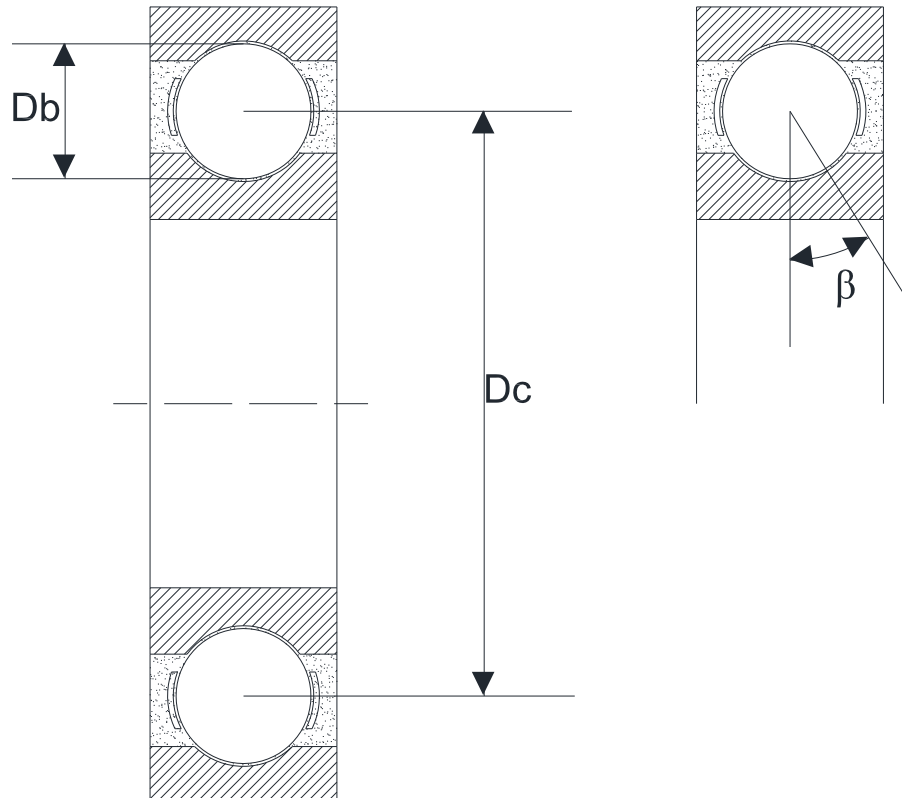

D_b ball diameter

D_c ball pitch diameter

β contact angle



SKF XL
Designed and developed
especially for large
wind turbine generators.

Rolling bearing race frequencies

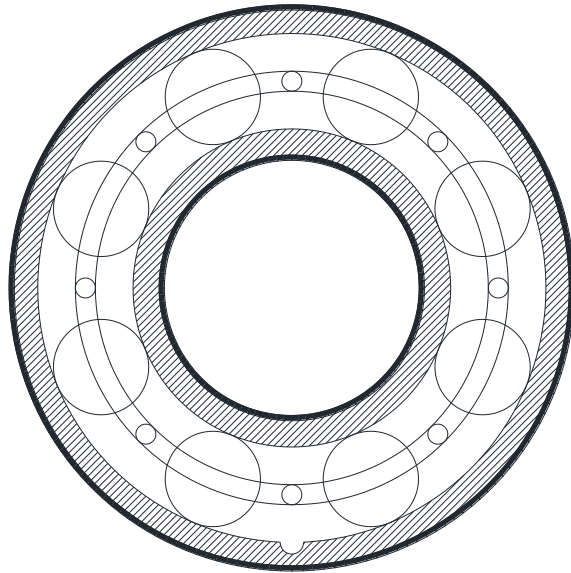

Outer race

$$f_{co} = \frac{N_b}{2} \left(1 - \frac{D_b}{D_c} \cos \beta \right)$$

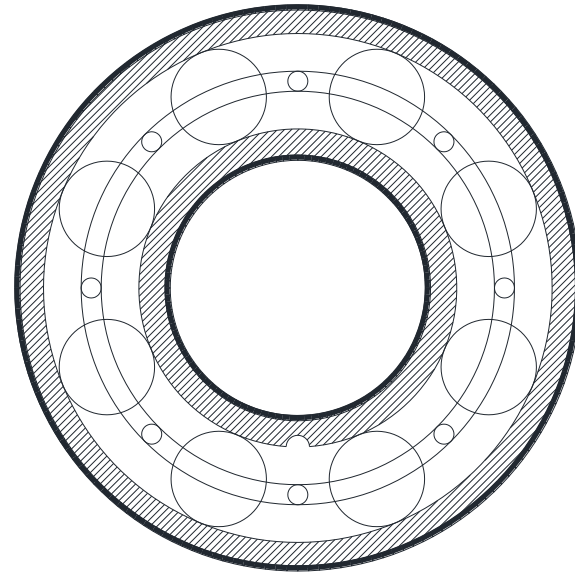

Inner race

$$f_{ci} = \frac{N_b}{2} \left(1 + \frac{D_b}{D_c} \cos \beta \right)$$

Air-gap variation

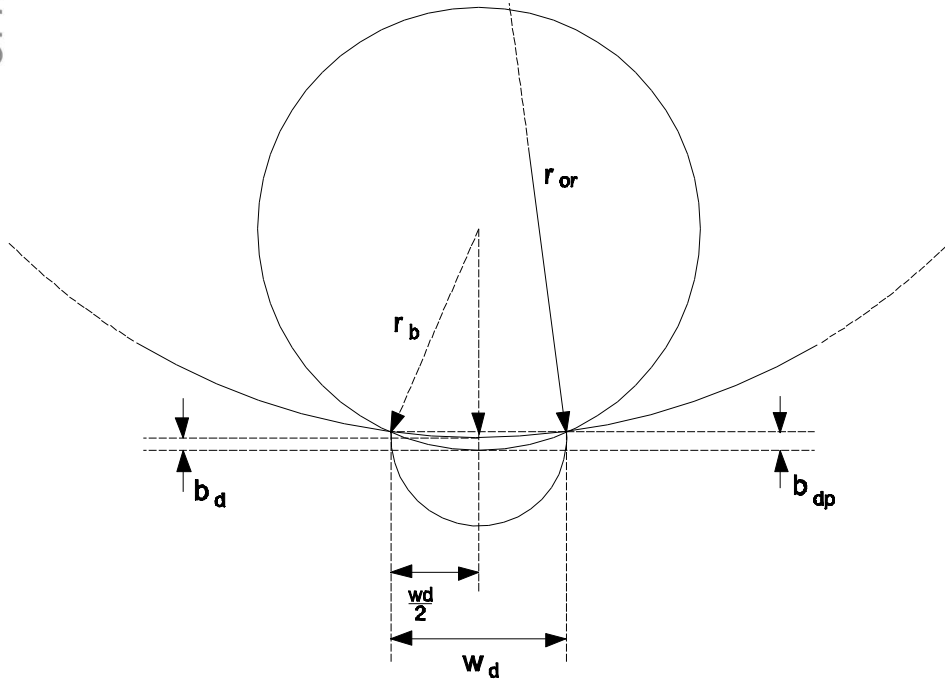

Ball drop

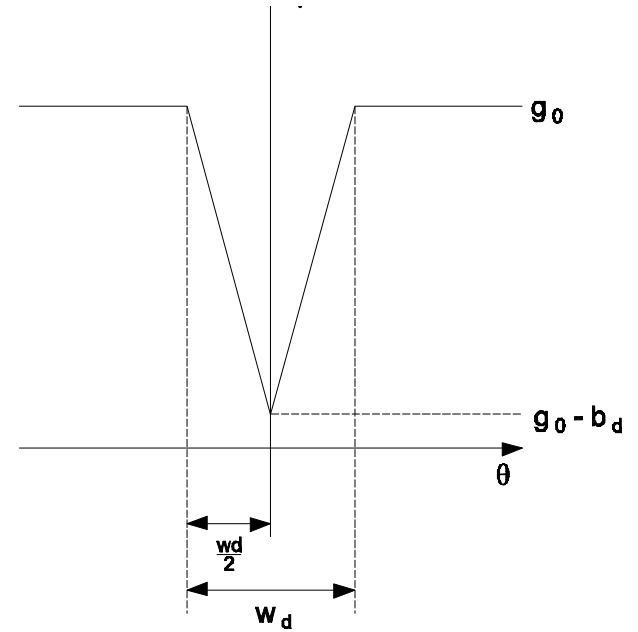

Air-gap variation

Eccentricity variation

$$g(\alpha, \theta) = g_0 - g_0 \delta(\theta) \cos(\alpha - \theta)$$

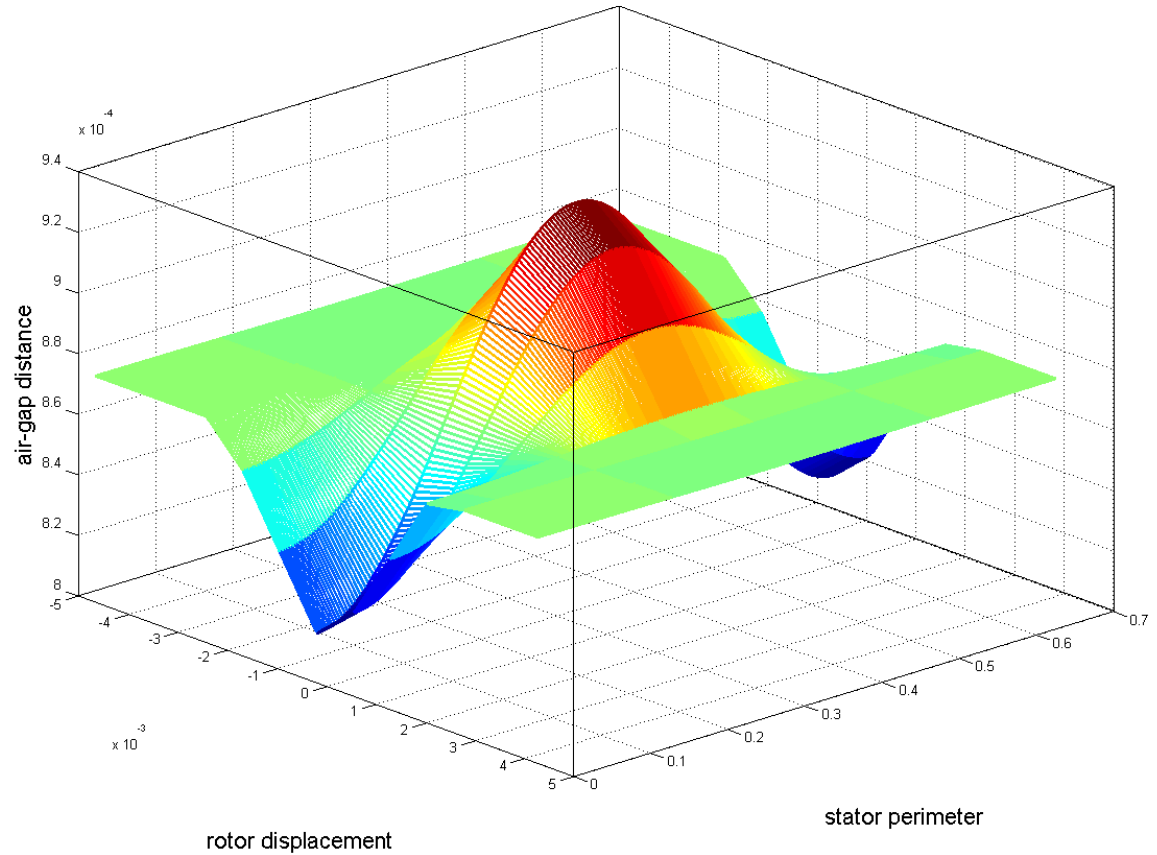
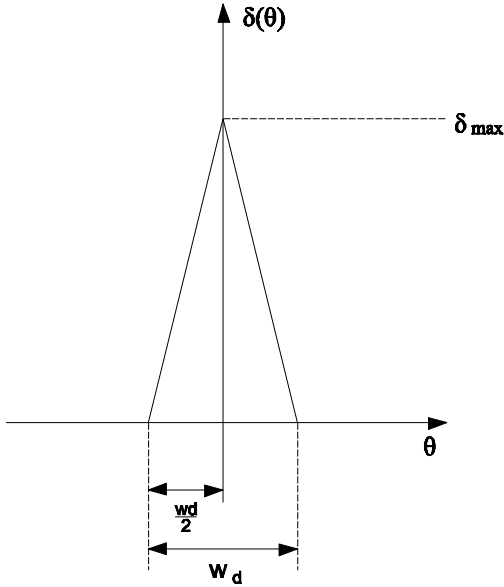

Ball bearing faults types



Flaking



False brinelling

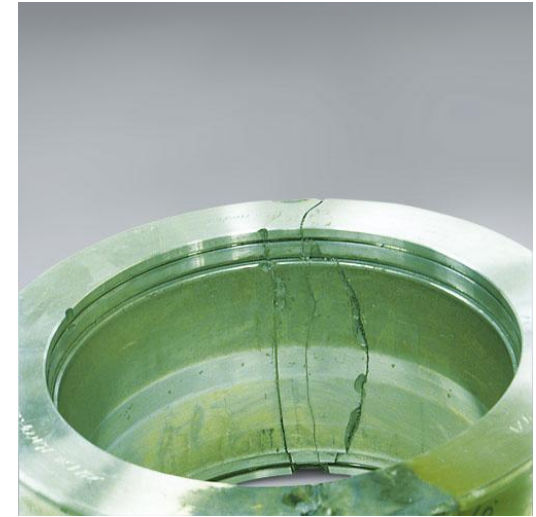

Crack

Machine model

- Based on coupled-circuit approach.
- A circuit is defined as 'any series connection of coils'.
- Complex conductor distribution is used to describe the spatial distribution of the windings
- Coupling inductances are calculated between circuits.
- Periodic eccentricity variation product of the bearing fault is considered
- Small air-gap variations are assumed
- Axial asymmetry is accounted for by halving the total eccentricity
- Analytical expression for machine inductances are obtained

Non-periodic machine inductances

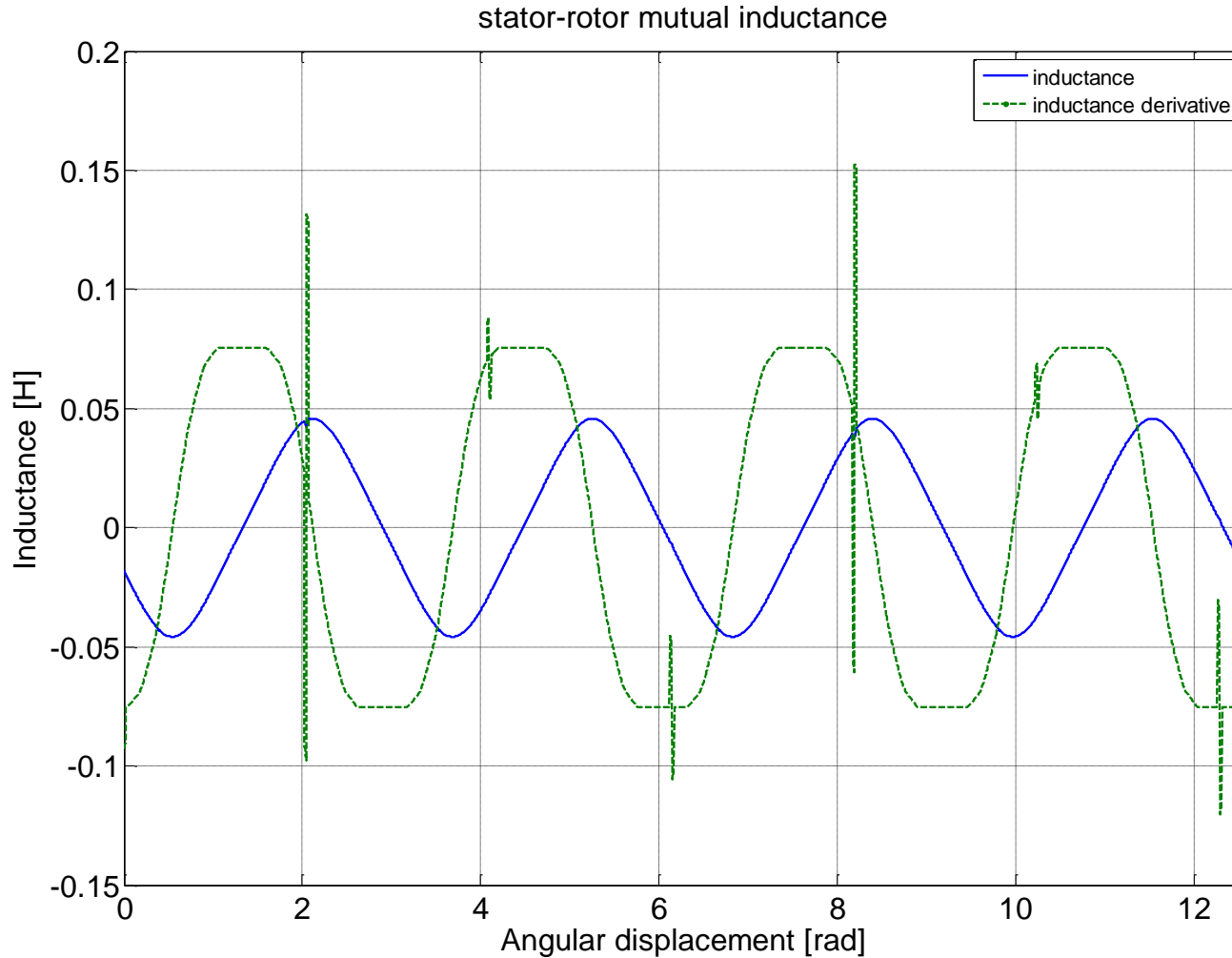

Simulation results

i_{as} frequency spectrum, 1600 rpm

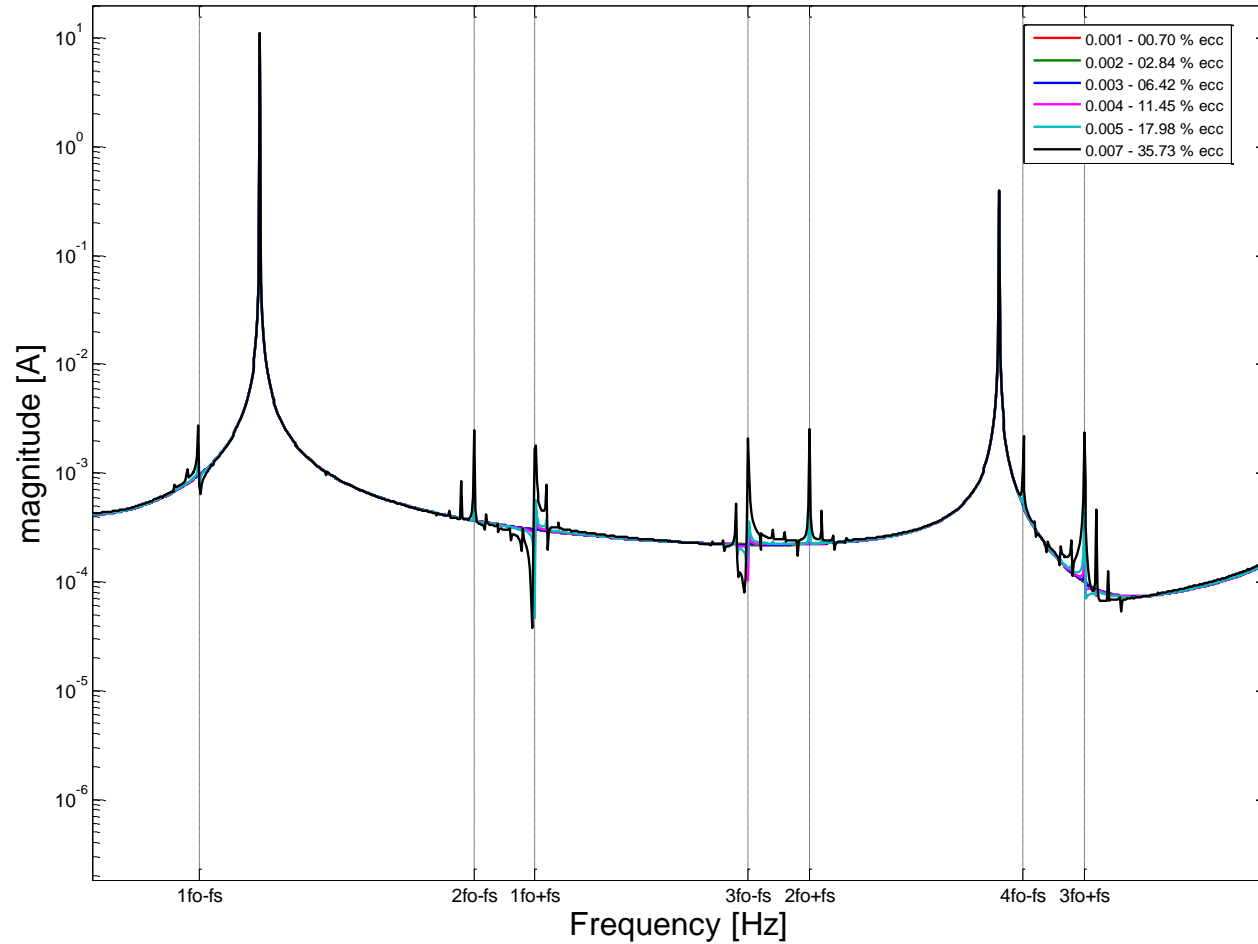

Bearing fault harmonics

- Outer race fault frequencies, $f_o = f_r f_{co}$

$$f_{or} = |fs \pm kf_o|$$

- Inner race fault frequencies, $f_i = f_r f_{ci}$

$$f_{ir} = |fs \pm kf_i|$$

- Increase with severity of the fault
- Are very small

Experimental rig

- 30 kW, 240 V wound rotor induction machine, 0.6 mm air-gap
- Short circuited rotor windings
- Parallel and series stator connection were considered
- Constant speed, driven by a DC motor
- Sub-synchronous and super-synchronous regimes were investigated
- The ball bearing in the load side of the machine was replaced between measurements
- SKF 6313-2Z/C3 ball bearings
- 8 balls, $D_c = 10.22$ cm $D_b = 2.381$ cm
- Contact angle, $\beta = 0$
- $f_{co} = 3.0679$, $f_{ci} = 4.9321$

Test Rig Description

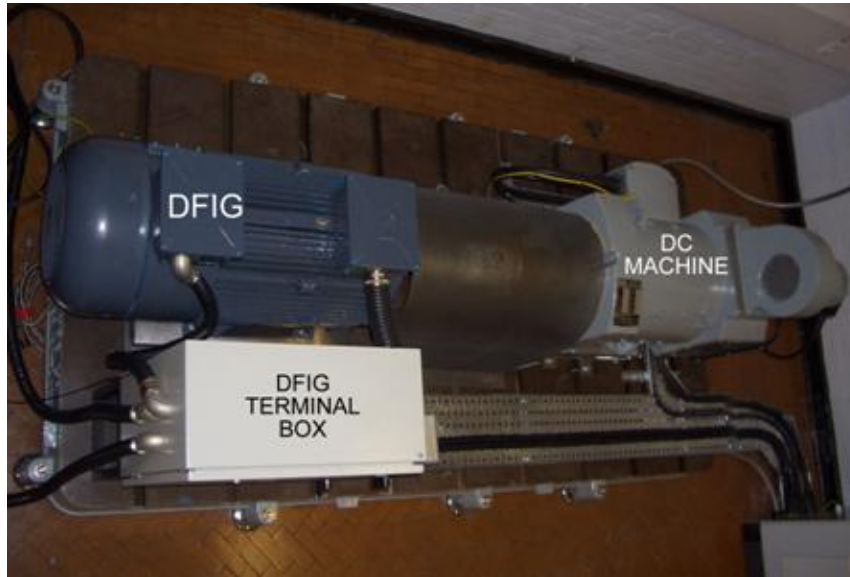

Laboratory test bed
(viewed from above)

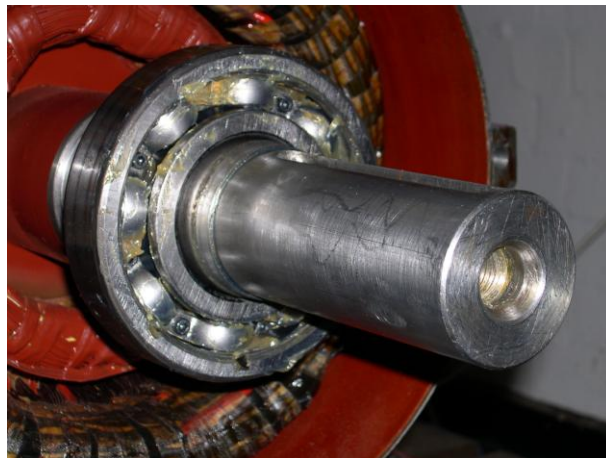

Load side
bearing

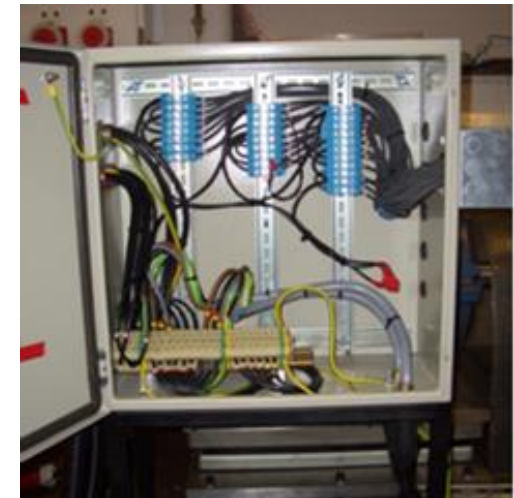

Terminal box

Experimental bearing fault simulation

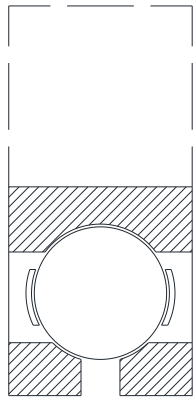

Outer race hole

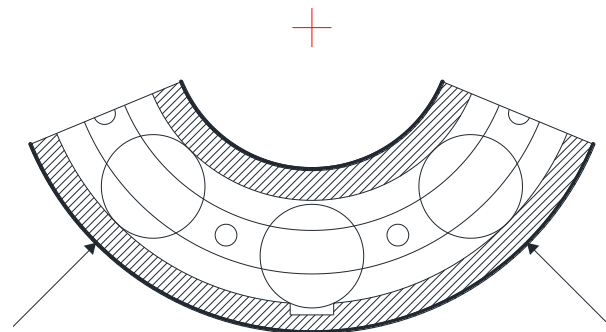

Outer race groove

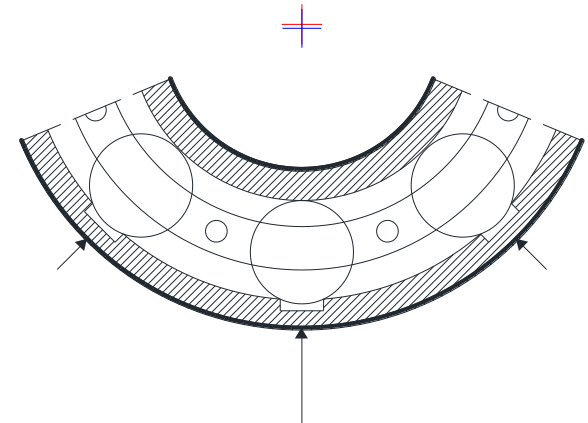

Experiment 626

Experimental results

stator current frequency spectrum, healthy machine

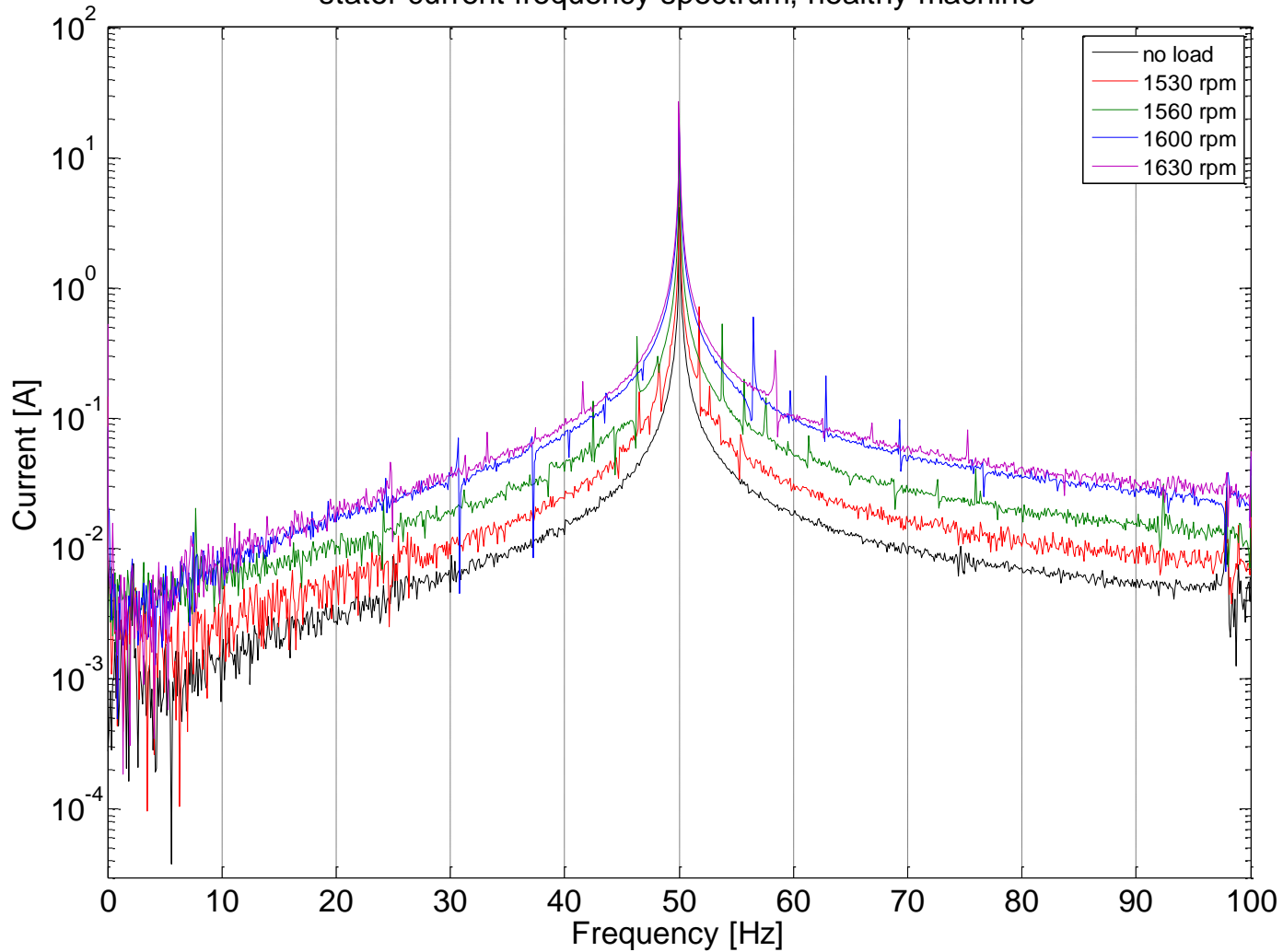

Experimental results

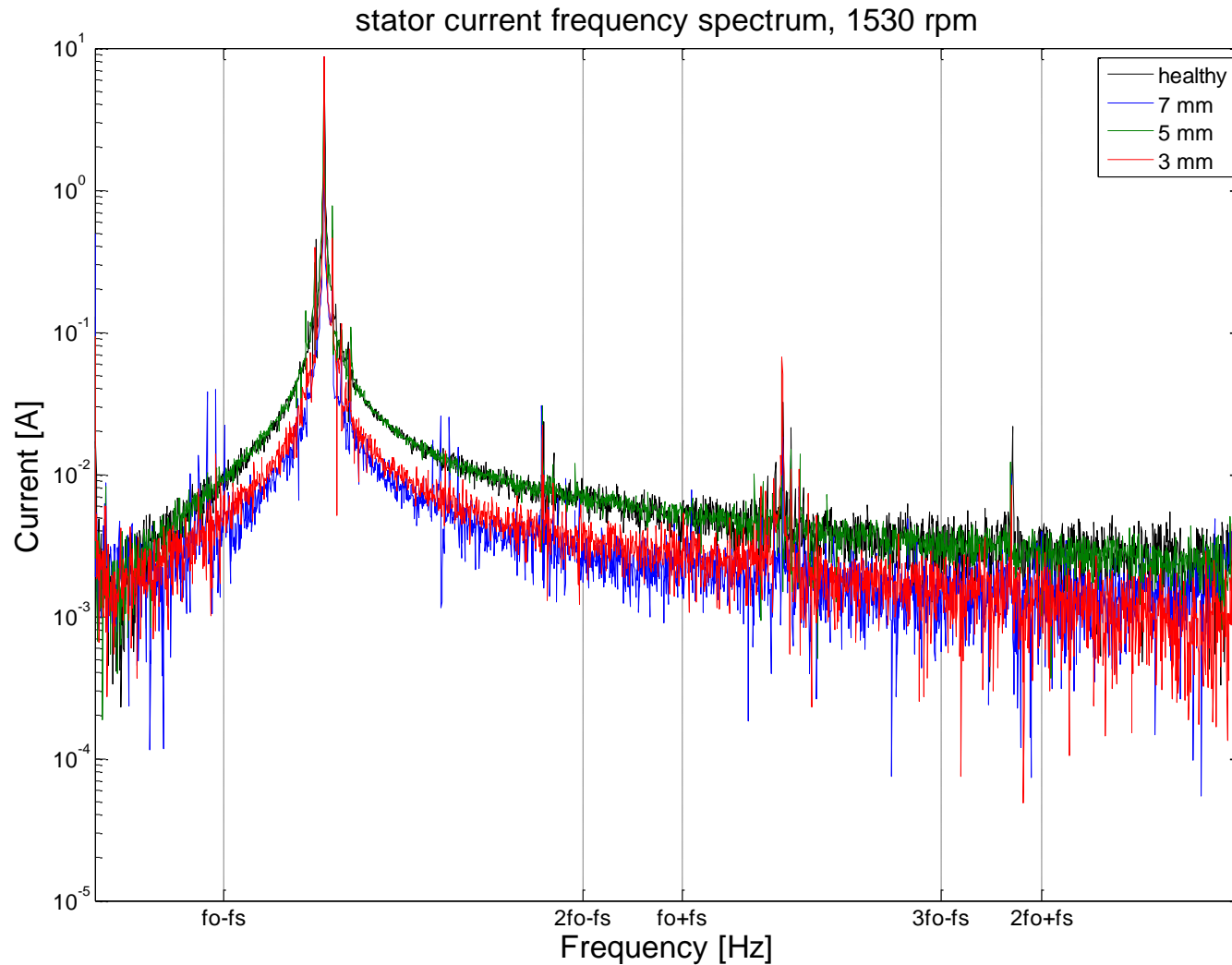

Experimental results

Stator current frequency spectrum, 1600 rpm

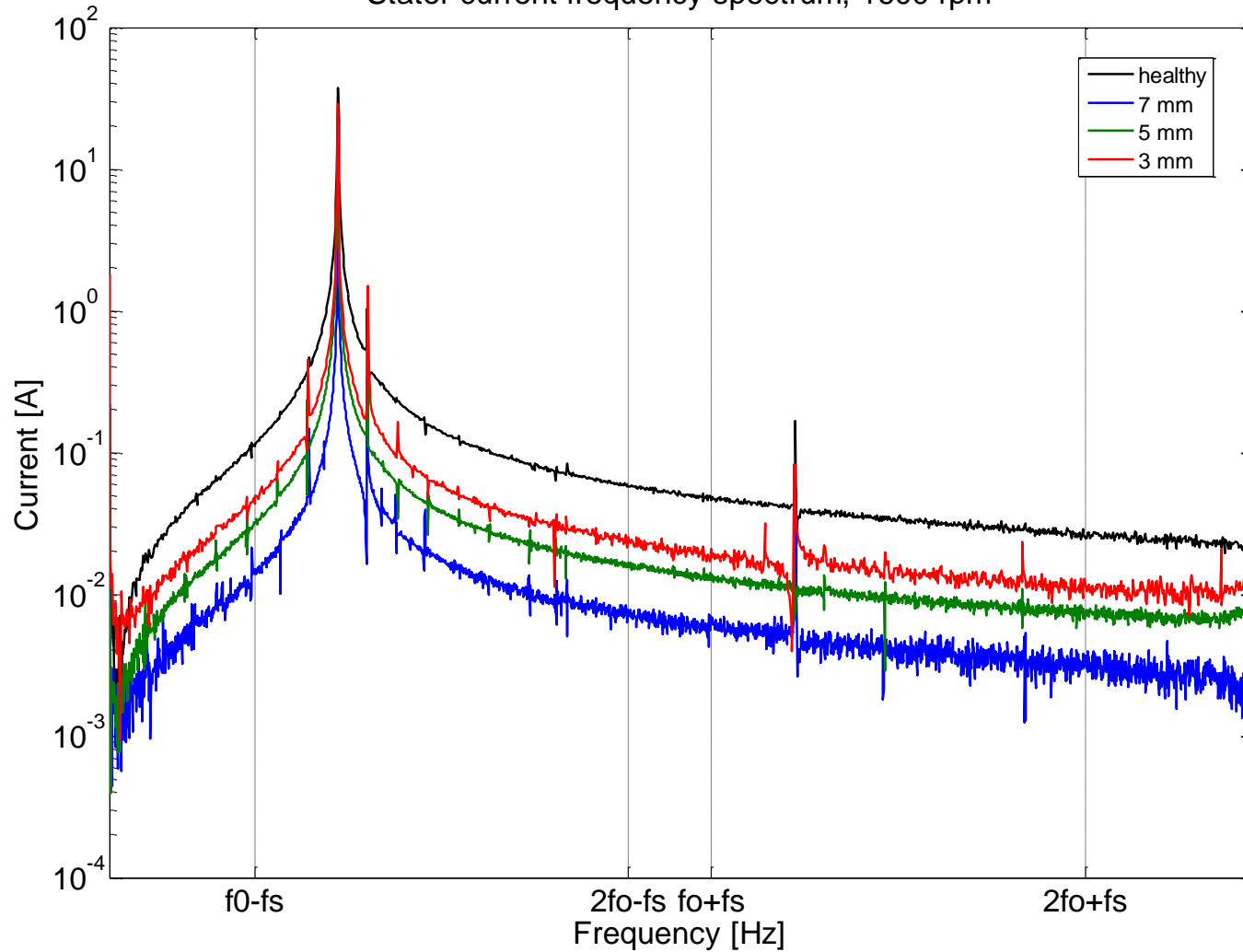

Experimental results

stator current frequency spectrum, 1630 rpm, 7mm fault

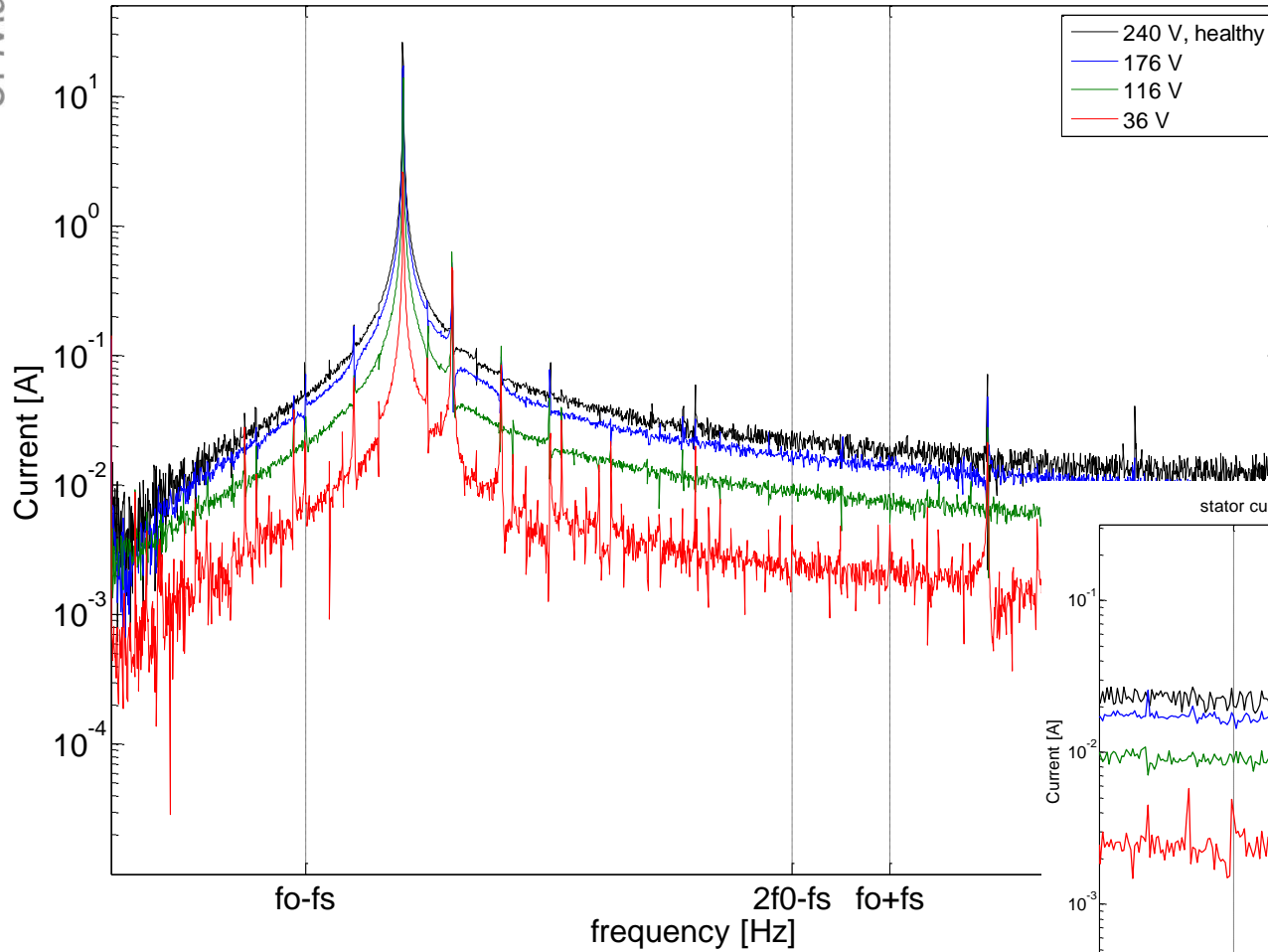

stator current frequency spectrum, 1630 rpm, 7mm fault

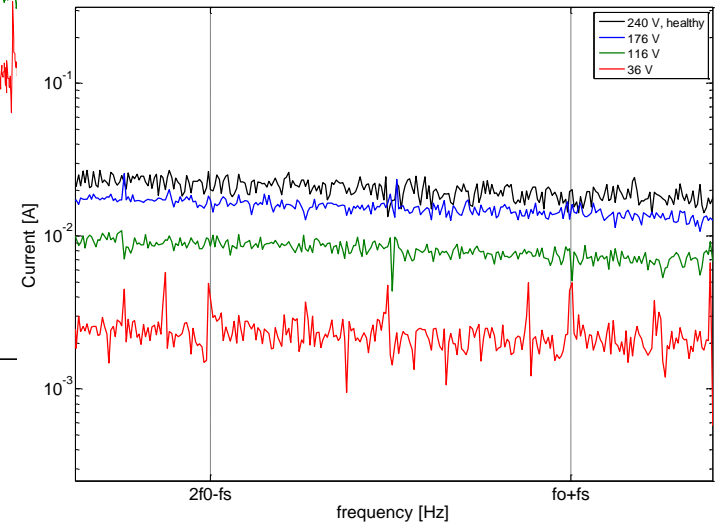

Experimental results

stator frequency spectrum, 1630 rpm, healthy

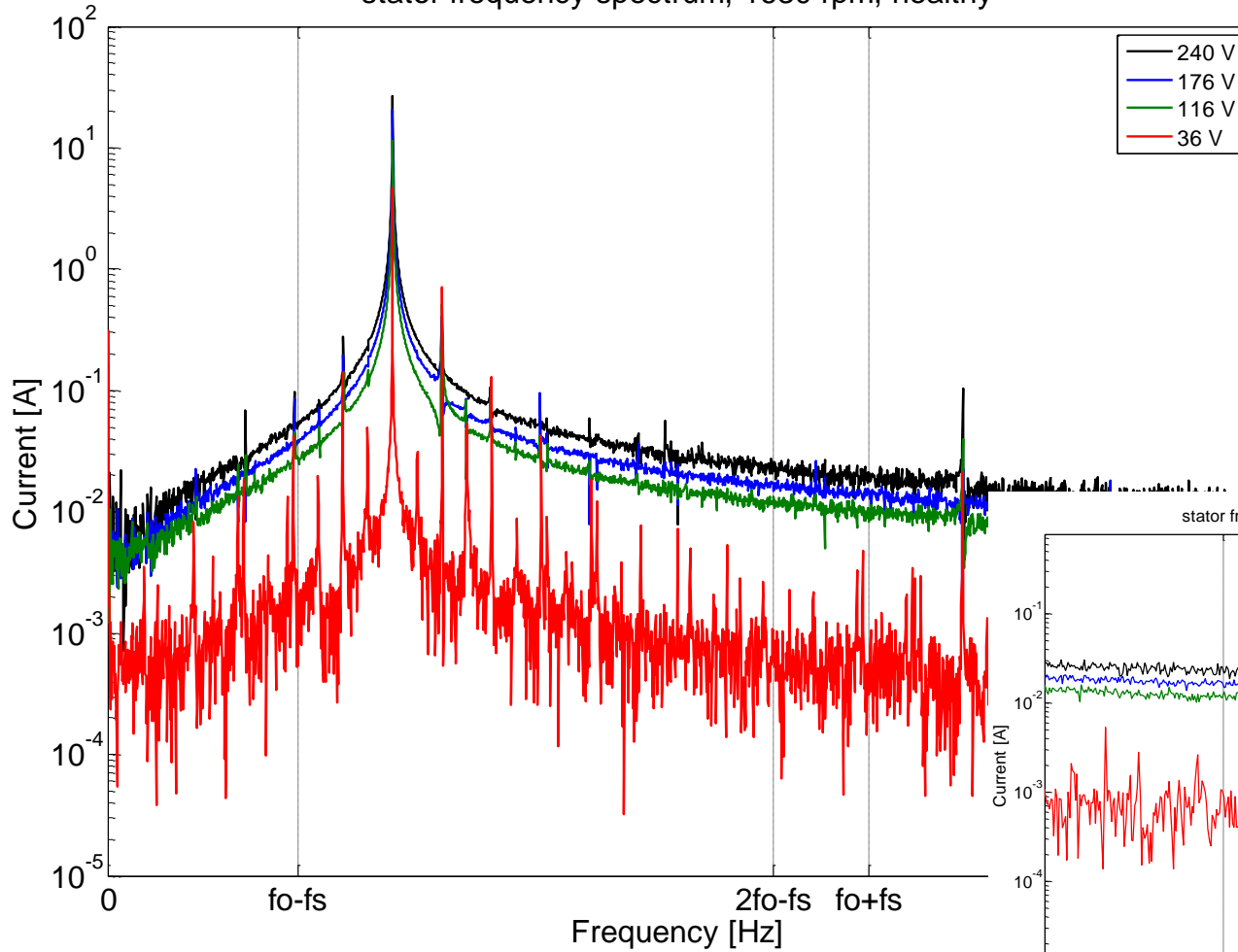

stator frequency spectrum, 1630 rpm, healthy

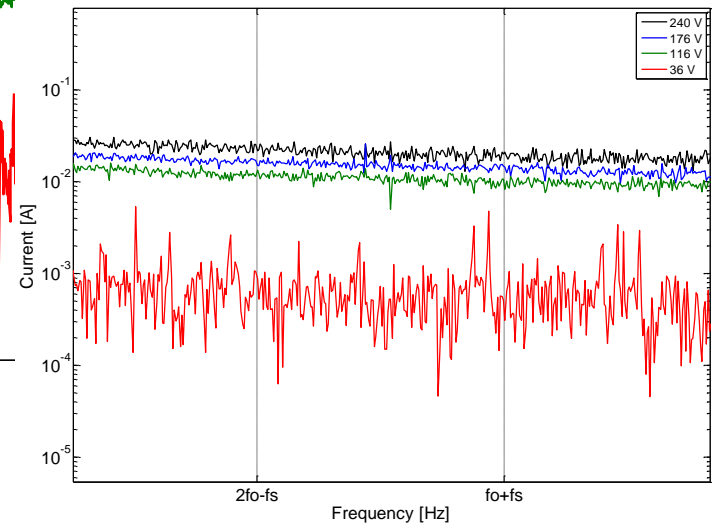

Conclusions

- Characteristic frequencies appear in the stator current spectrum as a consequence of a bearing fault
- Very small in magnitude, difficult to detect
- Below noise level in many cases
- Large faults may be detectable
- Additional signal processing techniques are required
- Not to substitute vibration analysis (complement)

Thank You