

Lightning Protection Of Wind Turbines

By

Vidyadhar Peesapati

Electrical Energy and Power Systems Group

University Of Manchester



LIGHTNING PROTECTION OF WIND TURBINES

- What is lightning?
Lightning is an electrical discharge in the atmosphere, very similar to a spark. It is the electrical breakdown of insulating air to provide a conductive path along which a current can run.
- An average bolt of lightning carries a current of 30 - 50kA, the highest reported to be 250kA.



Lightning and Wind Turbines

- What does a lightning strike require to form?
 1. A tall object capable of developing streamers or leaders
 2. Sharp edges where the field enhancement is high.
- ...Add these together, and a wind turbine, tall and its blades are the perfect set up for streamers that can attach themselves to incoming leaders.
- The blades are the most vulnerable parts to be damaged. Losses are incurred due to replacing these damaged blades and also due to downtime during replacement.
- All new blades are now protected with an inbuilt lightning protection system.

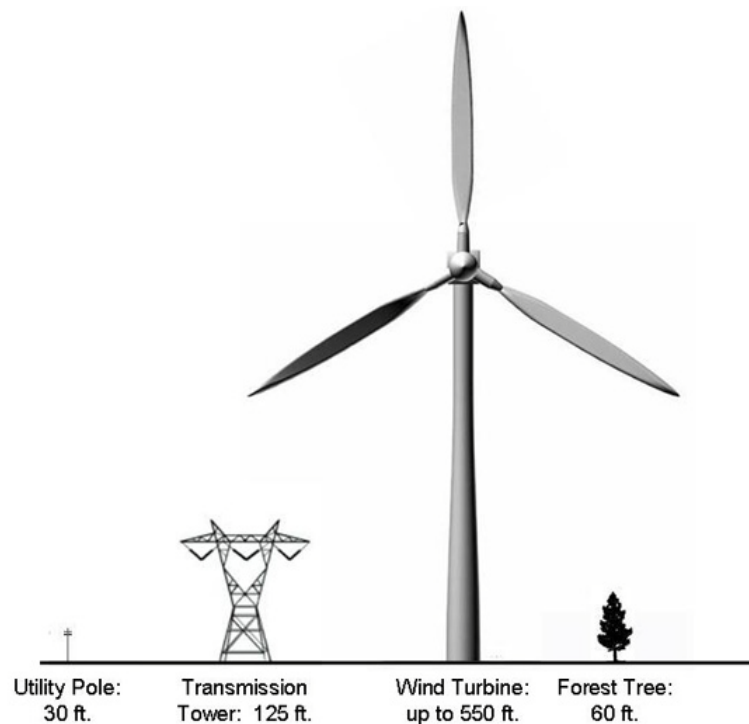

Lightning Protection Methods

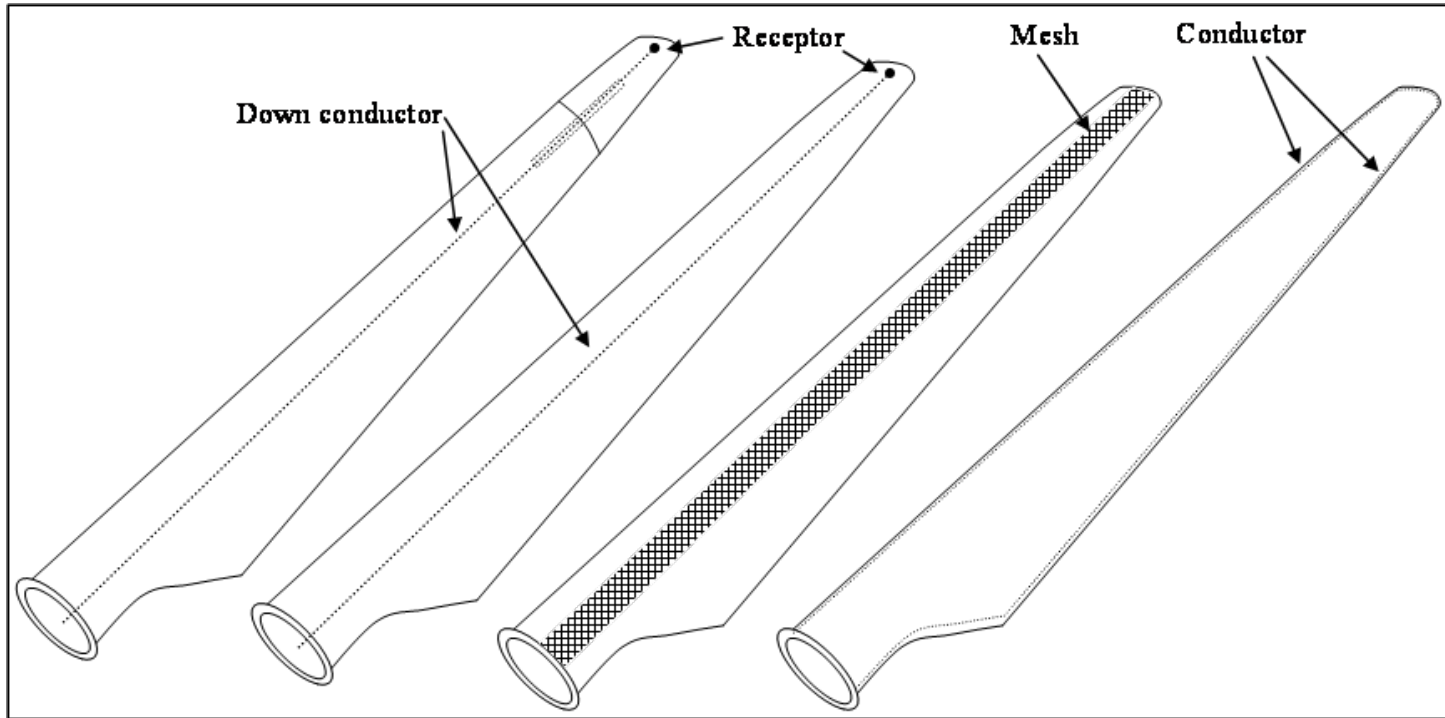

LPS on blades and working

- LPS is vital for wind turbine blades as they are prone to lightning strikes due to their shape and position on the wind turbine.
- LPS in the present blades in this project consist of a down conductor/ receptor based system.
- During a thunderstorm the receptor is the preferred first point of attachment to lightning leaders.
- After successful interception to the lightning leader, the lightning current is safely conducted through the down conductor

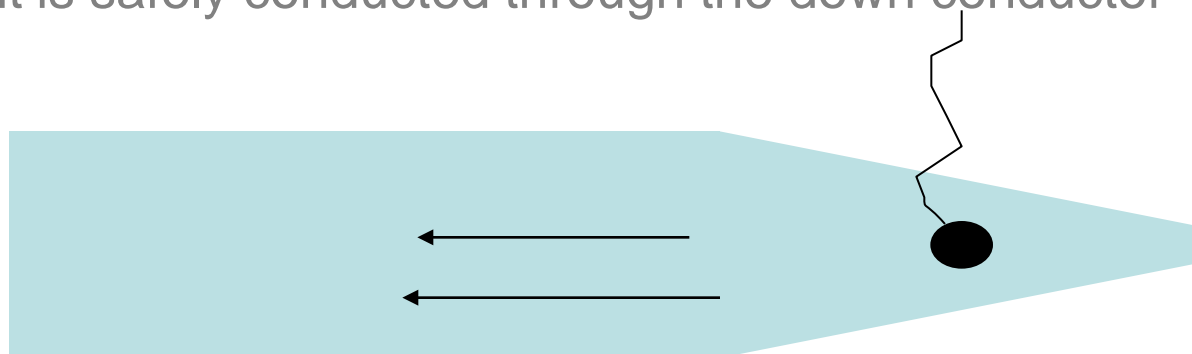

Lightning Damage

- Not all lightning strikes end up being intercepted by the receptor or the lightning protection points. Local damage to the area around receptors is still common.
- The main mechanism of damage is when the lightning current penetrates the blade and forms an arc inside.
- The pressure/shock wave could damage the blade, or cause cracks on the surface.



FEA Modelling Aims

- To create a wind turbine model in FEA software that can be used for upward lightning attachment modelling
- To determine the conditions required for successful leader inception and propagation.
- To determine the effect of cloud height on the lightning inception from a wind turbine, and to evaluate the ambient electric fields created due to a charged thunderstorm cloud
- To work with the radar side of the project and start to built FEA models with materials of stealth capability so as to find its effects on the existing lightning protection systems

FEA Modelling

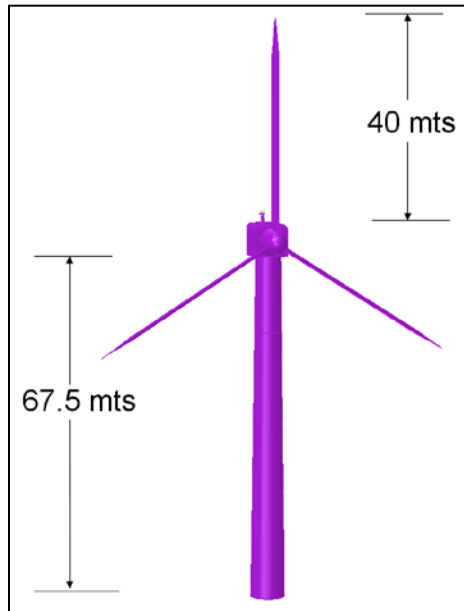

Wind turbine Model

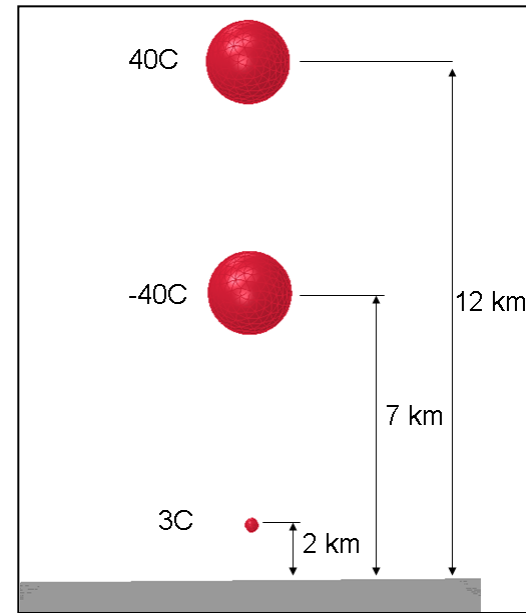

Cloud Model - Tripole

FEA Modelling - 2

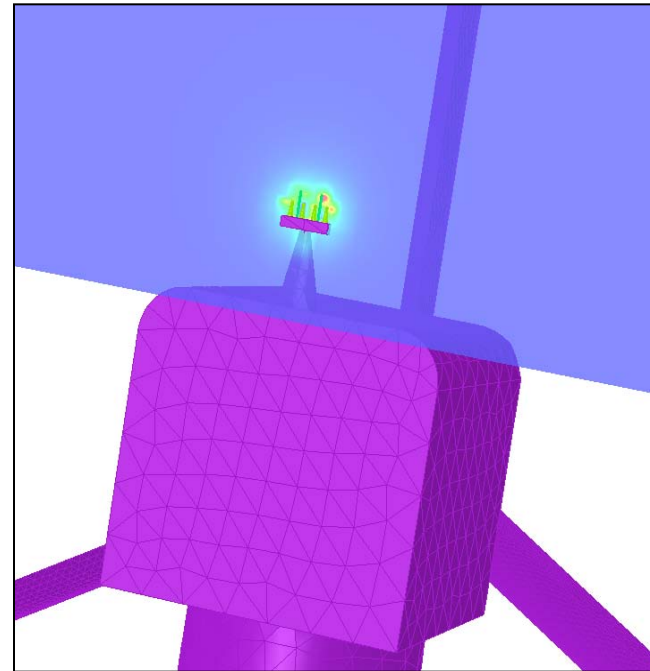
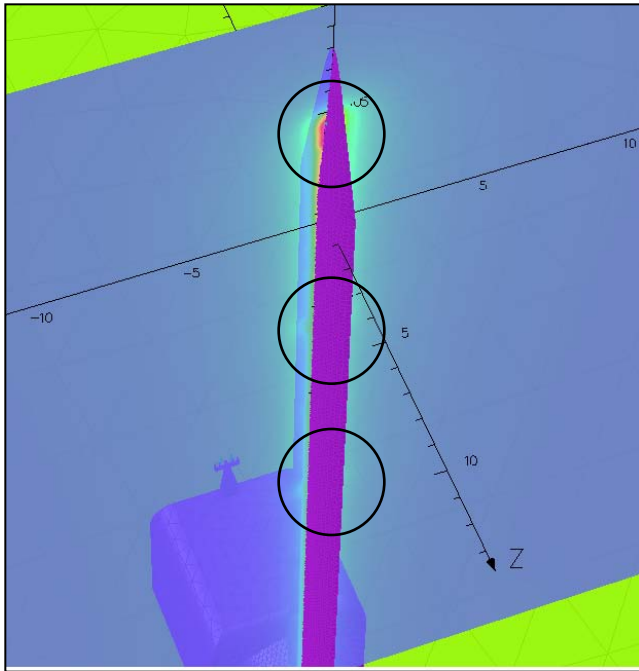

Field Enhancement at Blades and Windvane

Stealth Blade Solution - RAM

- ATC and Marine radar have had problems with wind turbines, especially offshore wind turbines. Images show ghost targets which are in reality not present.
- The model would consist of a 3 layer solution which would include a reflective surface and a high resistive layer in between the fiber glass layers.
- What impact would this have on lightning protection?
- FEA analysis performed for lightning attachment analysis.
- High Current Testing has been done on a Cu-Ni coated carbon fiber veil which could be used in the making of the stealth solution

Conflict between LPS and RAM Loaded Blades

- A decrease in the efficiency around the receptor
- Increase in risk of side flash
- Current conduction in carbon fibre/radar solution
- Enhanced field enhancement in bulk laminate
- Flashover between discontinuous radar patterns.



Lightning Impact Of RAM

- Two lightning protection solutions exist – mesh and receptor
- Present model is based on the receptor lightning protection solution (mesh solution would only work in terms of radar should a specific dielectric layer be placed above it)
- Initial model shows a significant change in the field enhancement on the down conductor (i.e. the internal blade field). This is a positive result as the chances on streamers inside the blade are minimised.
- However, the field around the receptors is significantly distorted and reduced
- Once lightning attachment has been established, the lightning protection system will have to conduct the lightning current without damage, this is tested by high current tests.

Cylinder model - Results

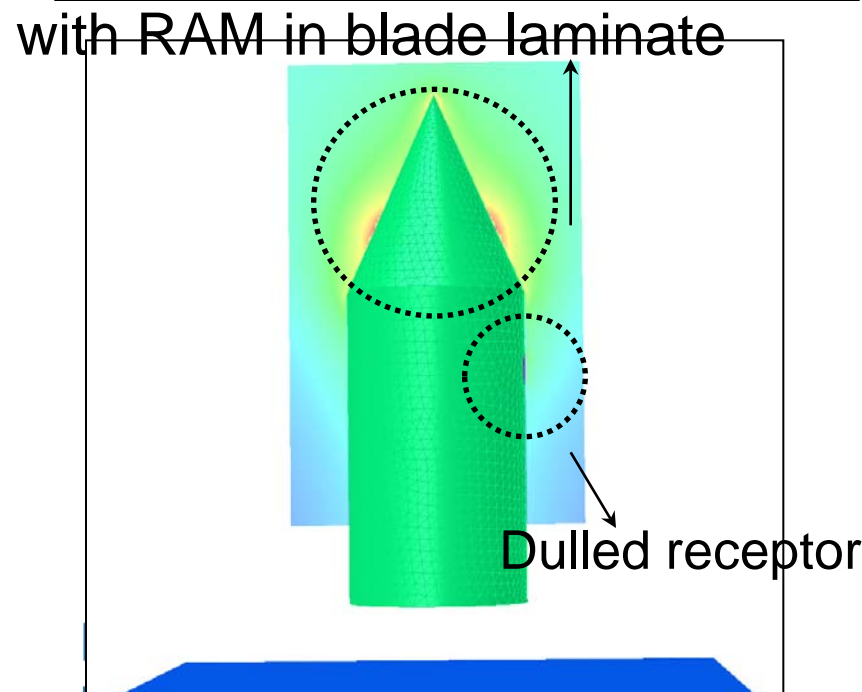
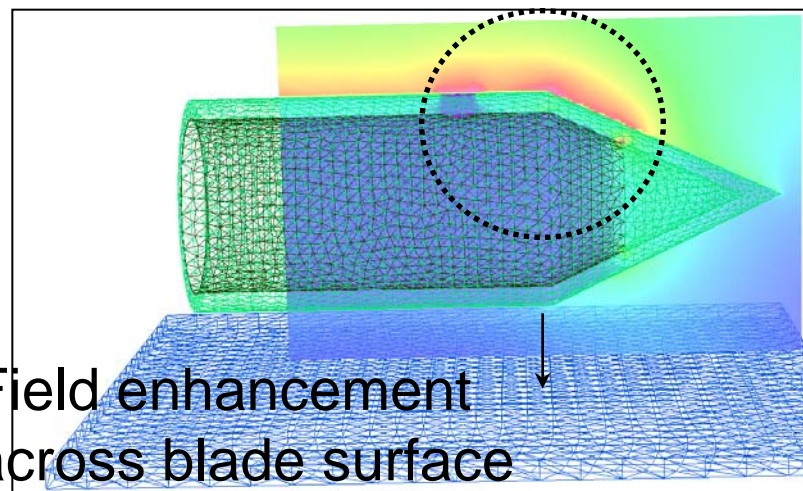
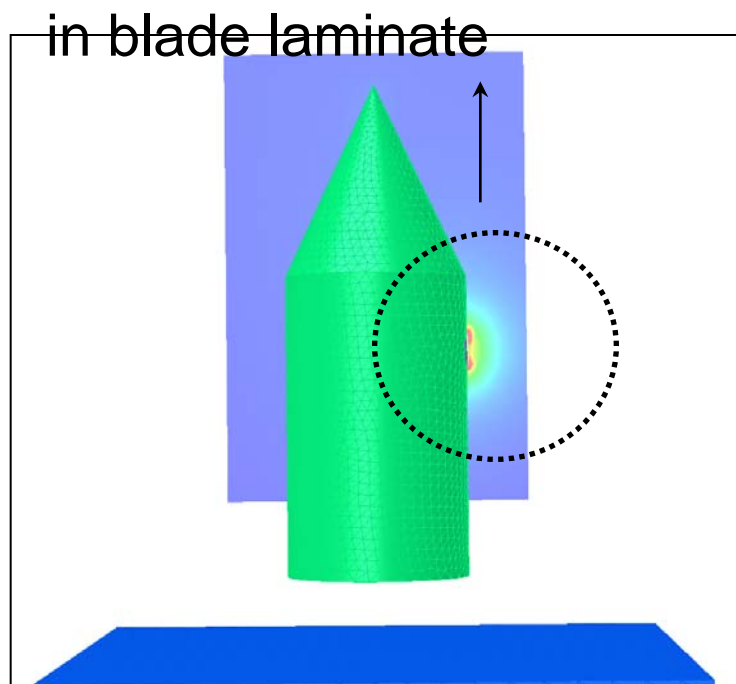
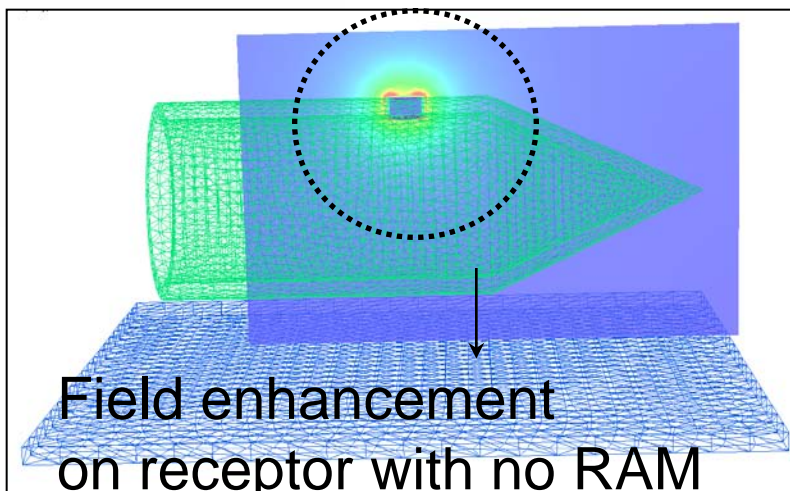

Impact on Lightning Current Conduction

- All lightning current carrying components needs to conduct and dissipate the energy without causing damage
- Existing lightning protection systems rated to carry lightning current and are tested to confirm this.
- The new composite layer will have to carry part of the lightning current (IEC standards require current conduction of 200 kA).
- All conducting materials will have to be electrically bonded.
- High Current tests were performed on the new composite layer.
- Composite tested as itself and also as a sheet infused with epoxy.



High Current Tests

- Samples of different lengths and widths were tested.
- Ideally layer should distribute strike energy evenly thus avoiding damage to other layers.
- Unfortunately it does not, even at currents levels around 15kA.

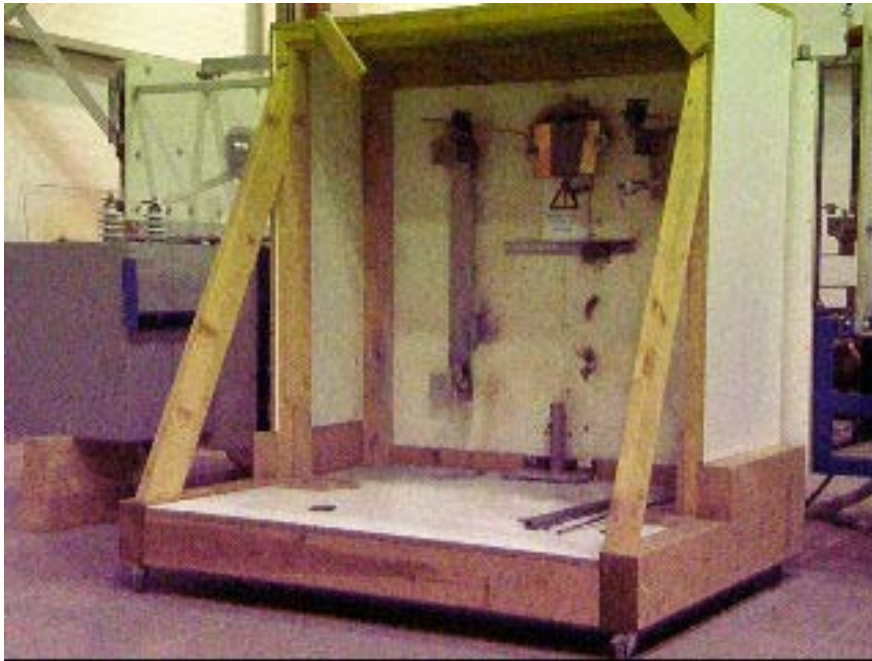

Before



After



Possible Solution – Selective Layering

- Can we give a clearance area around the air-terminations where the field is distorted and see if this improves the performance?
- Initial results still show an improved field enhancement around the receptor.
- But also there is a significant amount of field enhancement around unprotected parts of the blade, making it susceptible to lightning attachment.
- This is still a solution and different combinations of selective layering need to be analysed for a possible solution for the addition of a RAM solution to the blade.

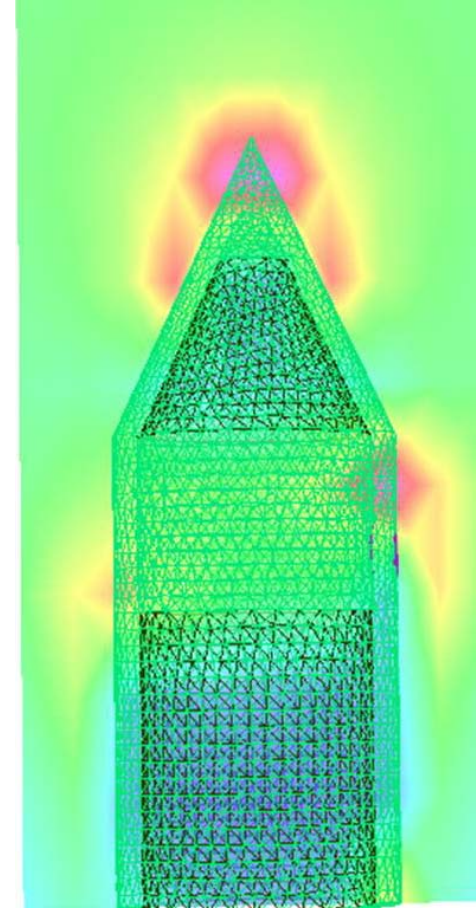

Material Enhancement

- Blue skies ideas relating to modification of blade surface properties in such a way that the receptor performance is enhanced
- Both permittivity and the conductivity of a material can be modified to improve the electric stresses on the surface of the blade.
- Through permittivity modification, can we maximise the field around the receptor while minimising the field within the blade material itself? i.e. Can we maximise the interception efficiency while reducing the risk of blade puncture
- Models based on varying permittivity are shown below

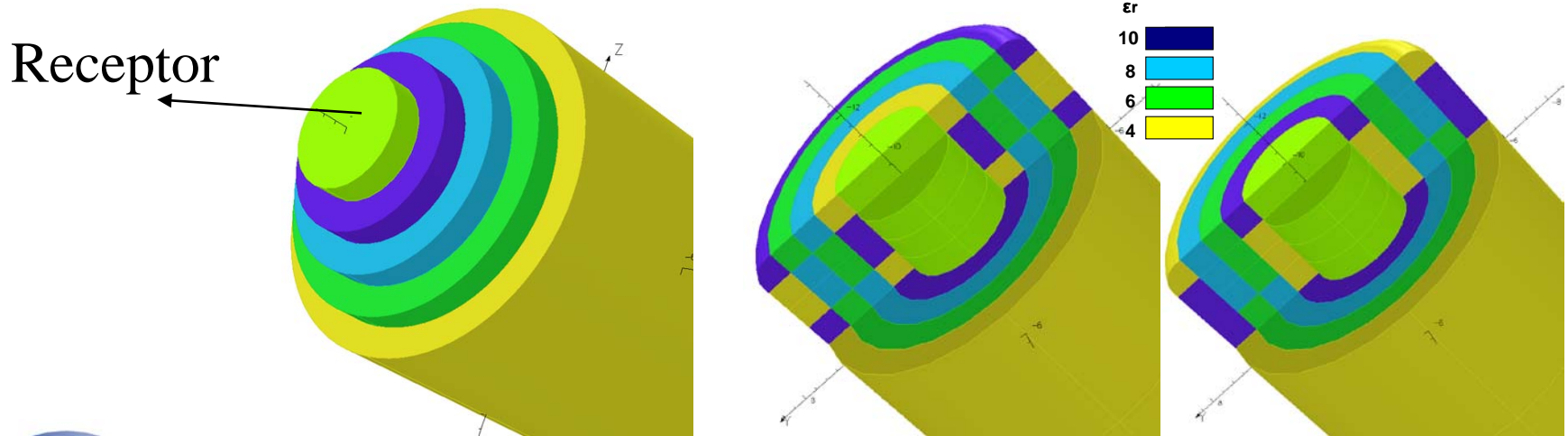

- High field in the bulk laminate is undesirable as this could lead to possible breakdown in the bulk laminate, causing punctures which can later evolve into hot spots for lightning attachment.
- The table below is an interpretation of the electric field enhancement on top of the laminate, in the bulk, and on top of the receptor
- Ideally the field in the bulk and on the top of the laminate should be as low as possible, leaving the receptor to the area of high field enhancement, thus the first place for streamers to develop.

	Field Enhancement Receptor (K_r)	Field Enhancement Glass Fibre (K_g)	Field Enhancement Bulk (K_b)
Descending	1.89	3.00	1.16
Ascending	2.10	3.35	0.24
Radial 1	1.98	2.94	1.33
Radial 2	1.95	3.08	1.85
No Material Manipulation	2.28	3.69	0.66

- Initial results show improved field enhancement, indicating the possible use of added fillers for better electrical performance.

Summary of Work

- The new stealth layer has a impact on the lightning protection system of the blade, by where it reduces the efficiency of the lightning protection system.
- FEA simulations highlight areas with no lightning protection show high field enhancement, thus at risk to lightning attachment.
- A combination of selective layering and material enhancement around the air terminations could be used to integrate the new layer into the blade laminate.
- Further FEA and testing and full scale HV tests could shed light onto the possible use of the above solutions.