

Brief Review of Recent Achievements in Durham

Condition Monitoring Techniques

Presented by Dr. W Yang, CJ Crabtree, Prof. PJ Tavner
4th March 2009

Wind Turbine Failures

European Wind Turbine Subassembly Failure Rates from 1993-2005

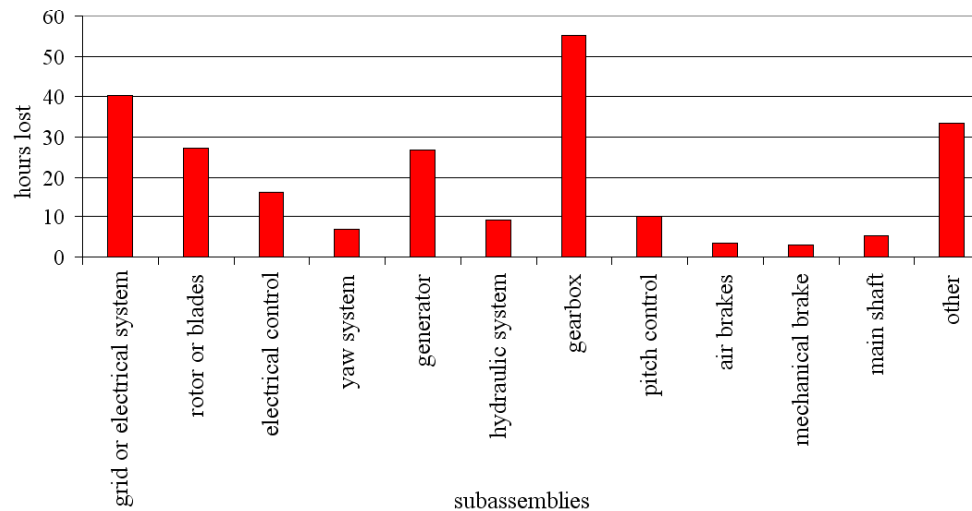
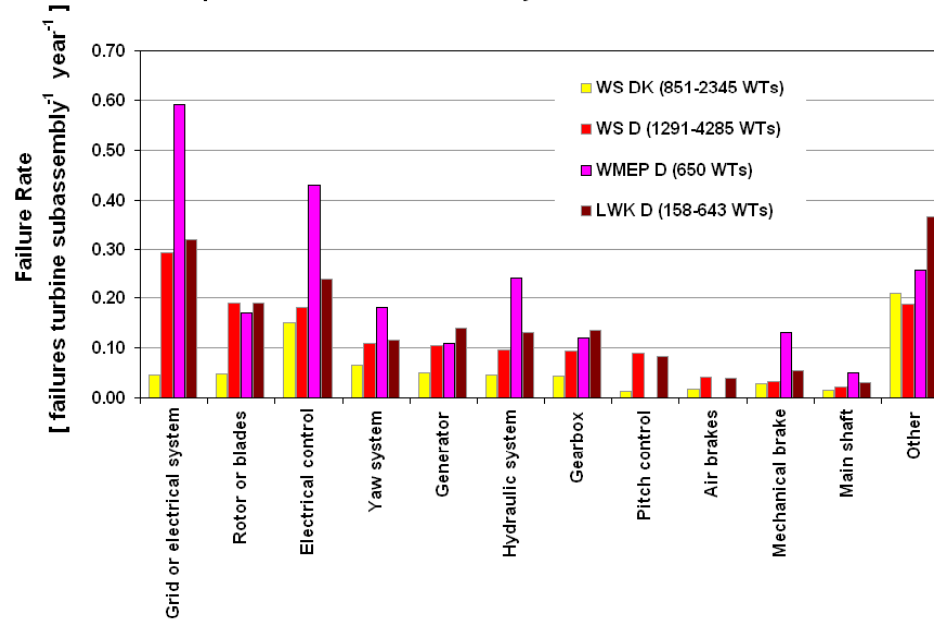

Condition Monitoring Systems

No.	Product	Supplier	Country	Means for condition monitoring & fault diagnosis	Sampling scheme
1	GE WT-CMS wind turbine condition monitoring system	GE (Bently Nevada)	USA	<u>Vibration</u> – main bearing, gearbox, generator, nacelle <u>Problem</u> : System has not been designed for the wind industry	Variable (probably up to 20kHz)
2	Vestas Wind turbine analysis system (WTAS) Type 3652	Vestas Vibro (Brüel & Kjær)	Denmark	<u>Vibration</u> – bearing, gearbox, generator <u>Acoustic</u> – noise in the nacelle by microphone	Variable, up to 40kHz
3	Siemens wind power Turbine condition monitoring system (TCM)	Siemens Wind Power AS (Gram & Juhl)	Denmark	<u>Vibration</u> – tower, blade, main bearing, shaft, gearbox, generator, nacelle	Unknown but variable
4	Nordex WT- wind turbine condition monitoring system (CMS)	Nordex (Prüftechnik)	Germany	<u>Vibration</u> – bearing, gearbox, generator	Unknown
5	RWE-CMS	RWE (Bently Nevada)	UK/USA	<u>Vibration</u> – gearbox, generator bearing, using high frequency transducer	Variable (probably up to 20kHz)
6	SCADA	Second Wind Inc.	USA	<u>Vibration</u> – drive shaft, main bearing, gearbox, blade, yaw drive, generator; <u>Temperature</u> -- main bearing, gearbox lubrication oil <u>Current/voltage</u> – generator	1/1s–10min
7	SKF WindCon	SKF.	Sweden	<u>Vibration</u> – main bearing, gearbox, generator <u>Acoustic emission</u> – main bearing, gearbox, generator (vibration in the 40kHz region) <u>Feature</u> : All of the inputs, power, vibration signals and communications are lightning protected.	Variable from a few Hz to hundreds kHz

Condition Monitoring Systems

8	WT-CMS	Bently Nevada (GE)	USA	<u>Vibration</u> – main bearing, gearbox, generator, nacelle <u>Problem</u> : System has not been designed for the wind industry	Variable (probably up to 20kHz)
9	WTM-8	SWANguard	USA	<u>Acoustic emission</u> – bearing, gearbox	Hundreds kHz
10	Ultra-Trak 750	UE Systems Inc.	USA	<u>Ultrasonic</u> – bearing, gearbox	>80kHz
11	Wind turbine analysis system (WTAS) Type 3651	Brüel & Kjær Vibro	Denmark	<u>Vibration</u> – nacelle, shaft, main bearing, gearbox, generator <u>Temperature</u> – ambient temperature in the nacelle and in generator bearings	Once a few minutes to 20kHz
12	Turbine condition monitoring (TCM)	Gram & Juhl	Denmark	<u>Vibration</u> – tower, blade, main bearing, shaft, gearbox, generator, nacelle	Unknown but variable
13	WT-CMS a.VIBNODE (permanent) b.VIBROWEB XP c.VIBXpert (portable)	Prüftechnik Condition Monitoring GmbH	Germany	<u>Vibration</u> –bearing, gearbox, generator	Unknown
14	WP4086	Mita-Teknik	Denmark	<u>Vibration</u> –bearing, gearbox, generator, 8 accelerometers are used	Unknown
15	E-GOMS	Eickhoff	Germany	<u>Vibration</u> –bearing, gearbox, generator <u>Problem</u> : 8 channels are multiplexed, i.e. channels are sampled in turn, not simultaneously	Unknown
16	a. FAG WiPro b. FAG ProCheck	FAG Industrial Services	Germany	<u>Vibration</u> – gearbox, bearing	Up to 50 kHz
17	WinTControl	Flender Service GmbH	Germany	<u>Vibration</u> –bearing, gearbox, generator	32.5kHz

Condition Monitoring Systems

18	FAG WiPro	FAG Industrial Services GmbH	Germany	<u>Vibration</u> – tower, blade, main bearing, shaft, gearbox, generator (also <i>torque, temperature and oil analysis</i>)	Adjustable
19	E-Sentry System	Global Maintenance technologies	UK	<u>Vibration</u> – bearing, gearbox, generator	Unknown
20	AE system	Holroyd Instruments	UK	<u>Acoustic emission</u> – bearing, gearbox <u>Problem:</u> System has not been designed for the wind industry	>80kHz
21	SPM	SPM Instruments	Sweden	<u>Vibration</u> –bearing, gearbox	Unknown
22	SMP-8C	Gamesa Eolica	Spain	<u>Vibration</u> –main shaft, gearbox, gearbox	Unknown
23		Insensys	UK	<u>Strain</u> -blade strain using fibre optics	<0.017Hz (1min)
24	PCM200	Pall Europe Ltd	UK	<u>Cleanliness</u> – Hydraulic, cooling and lubrication oil <u>Water Sensing</u> - Probe WS05S <u>Differential Pressure</u> - Delta Sense transducer	Unknown
25	Particle counter	Hydac International GmbH	Germany	<u>Cleanliness</u> – Hydraulic, cooling and lubrication oil	Unknown
26	a.TechAlert™ 10 (Ferrous & Non-Ferrous metallic debris detection) a.TechAlert™ 20 (Ferrous metallic debris detection)	MACOM	UK	<u>Cleanliness</u> – Hydraulic, cooling and lubrication oil	Both are online system. But their sampling frequencies are unknown

Difficulties in Available Systems

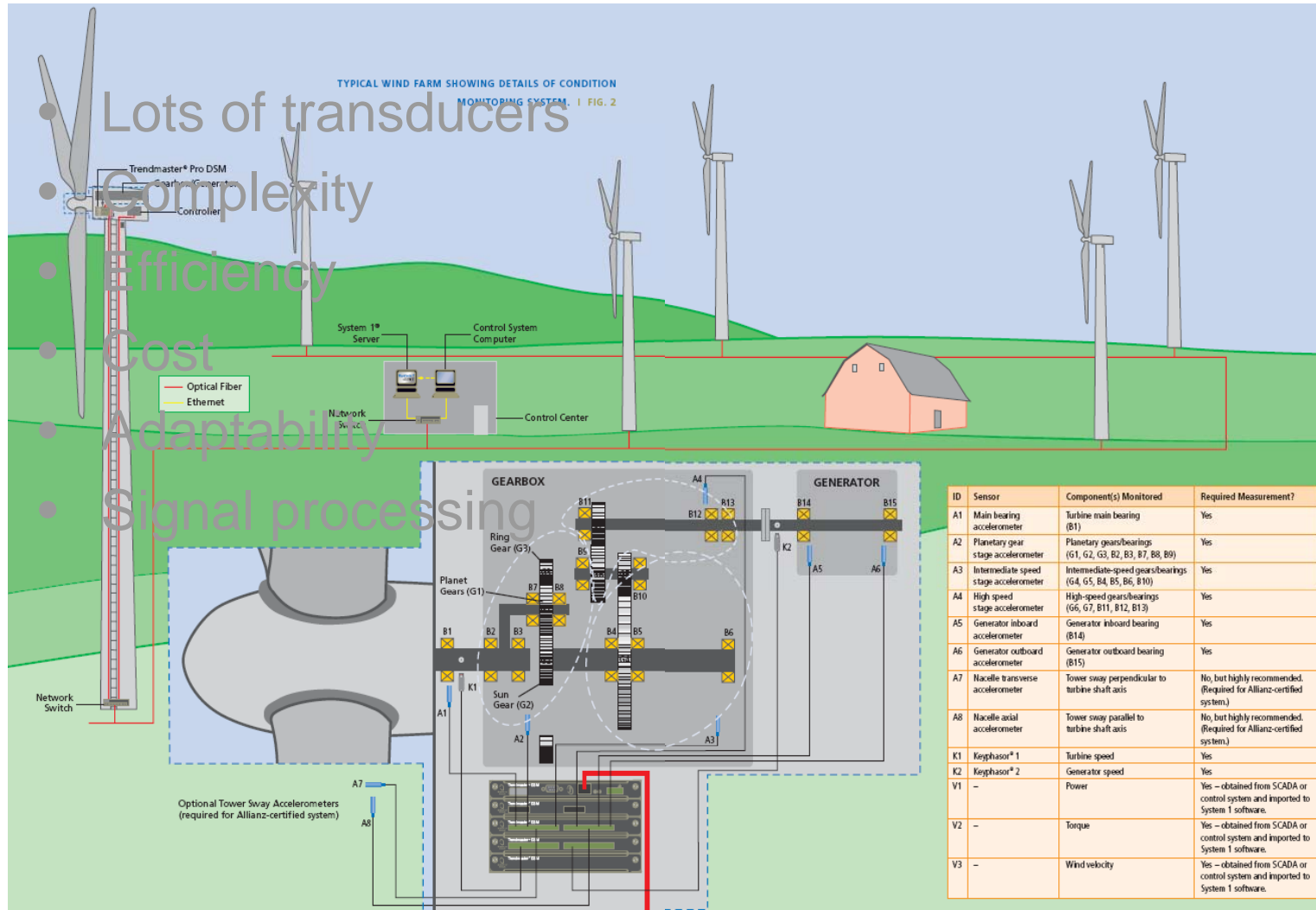

Recent Achievements at Durham



The Durham Test Rig

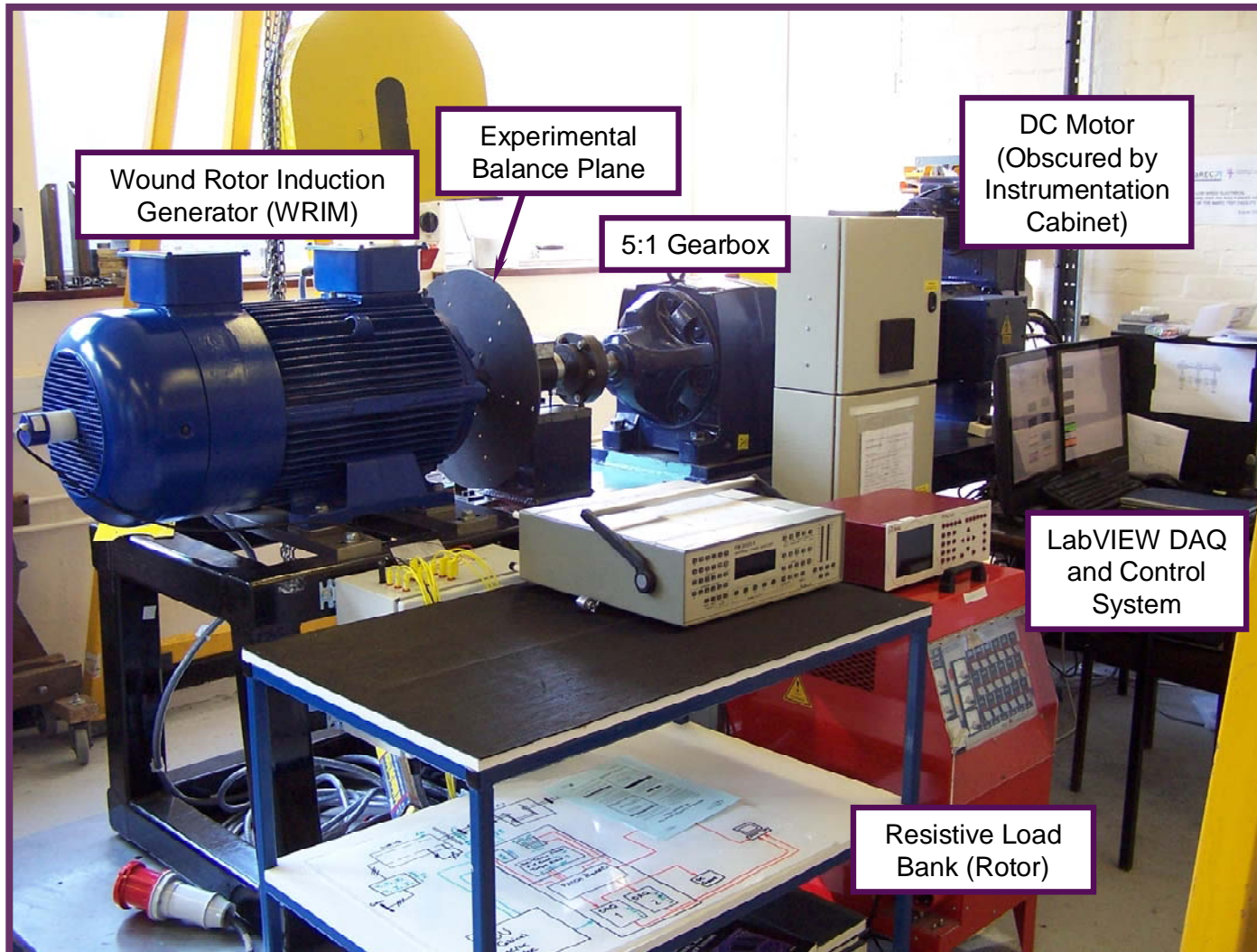

The Durham Test Rig

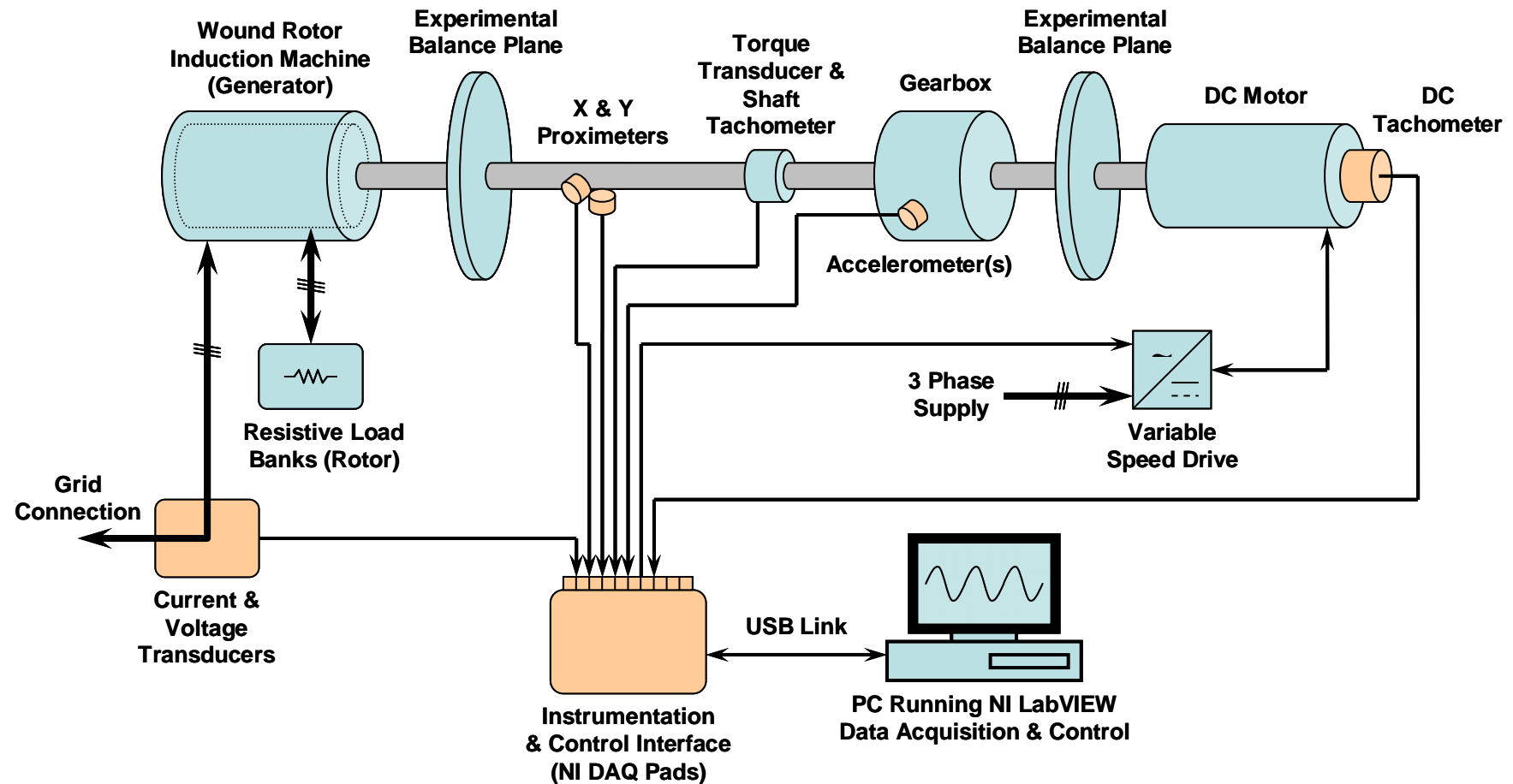

Induction Machine Model

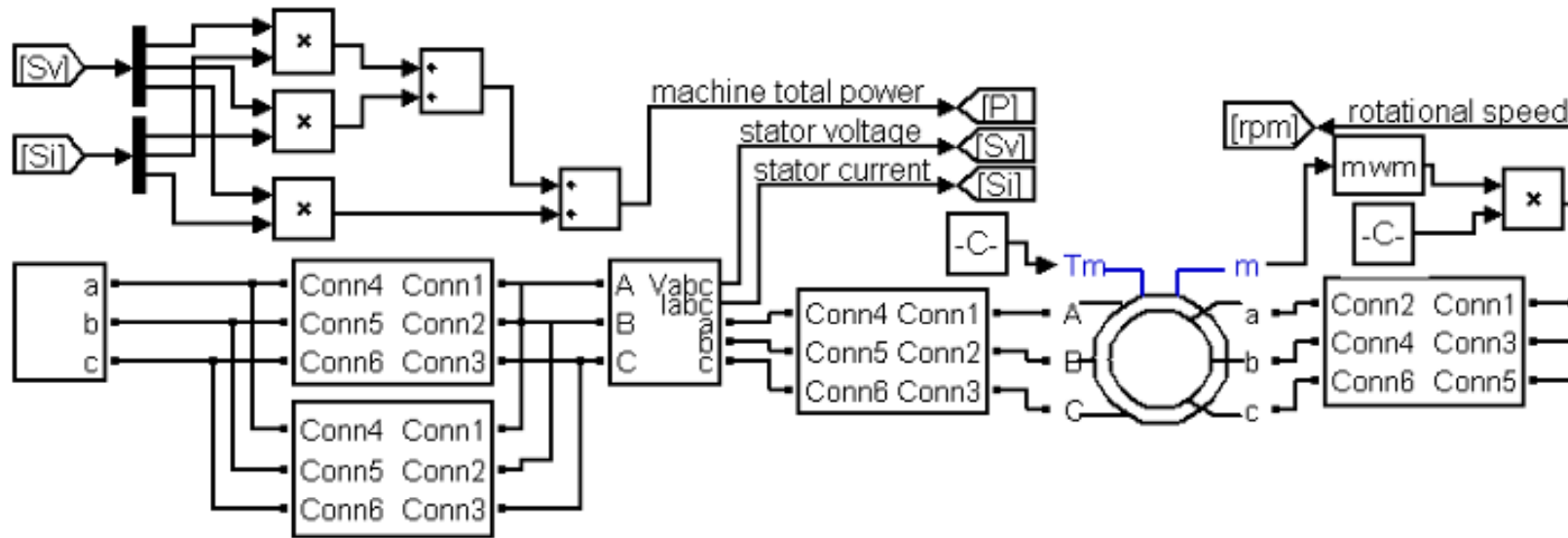

Model Signals

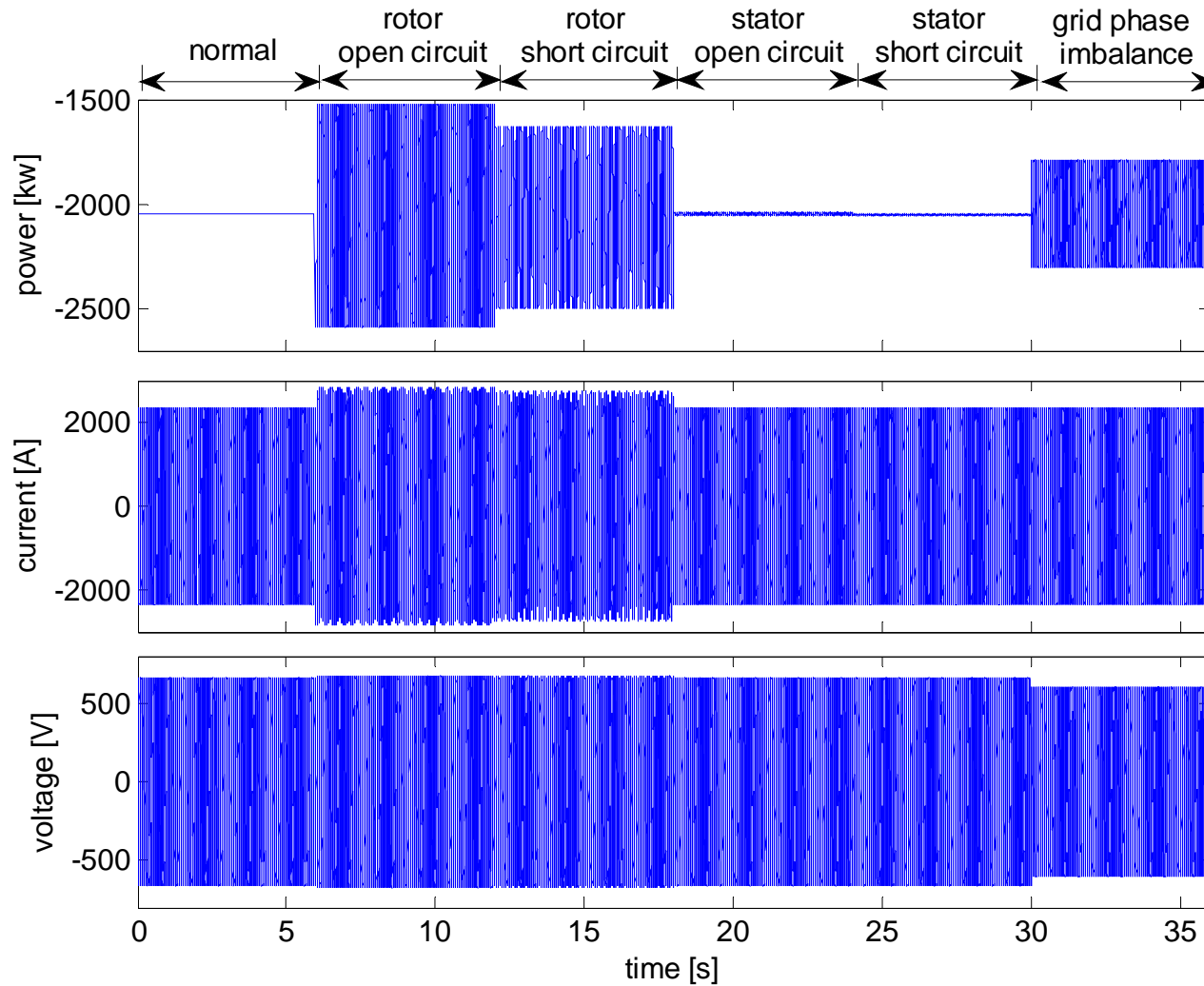

Model Spectrum

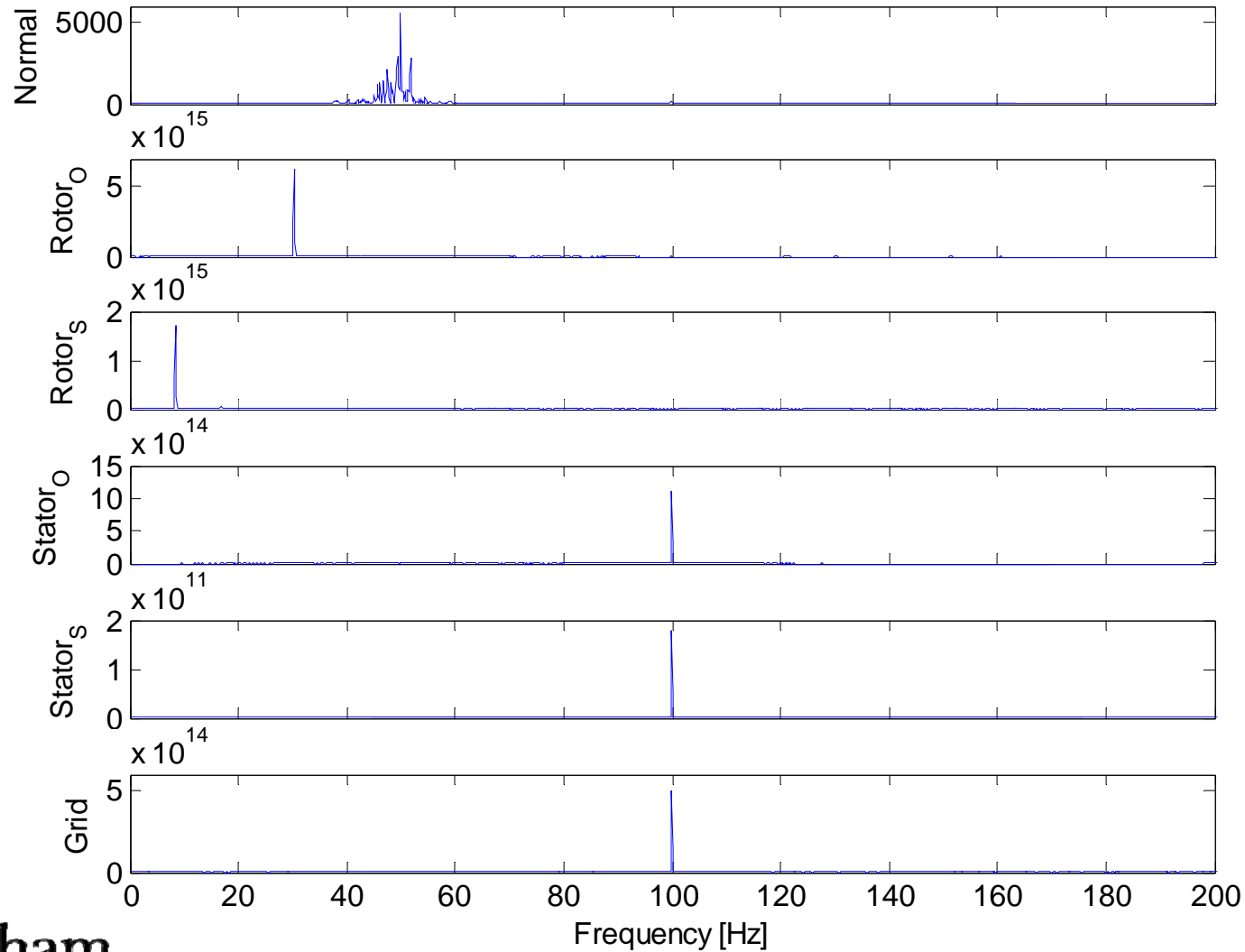

Experiments and Achievements

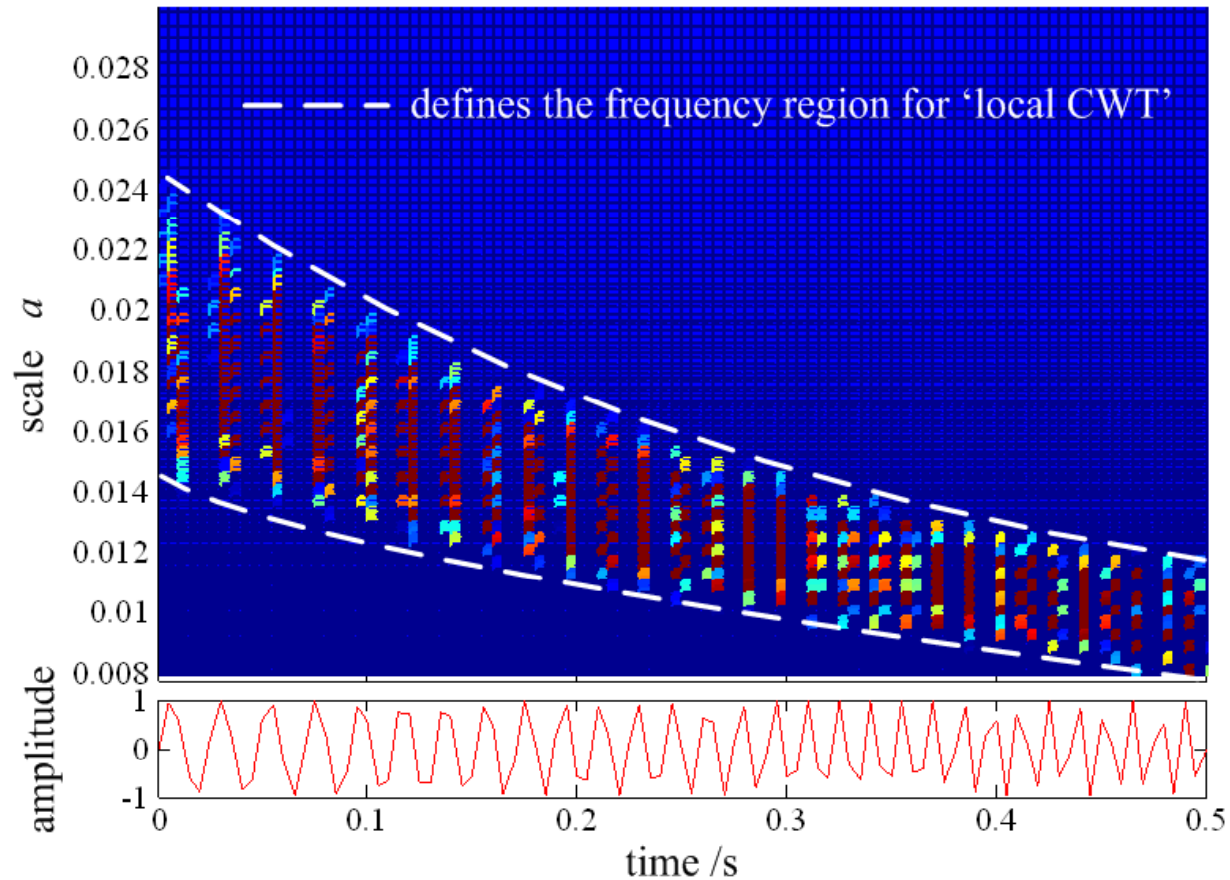

Results

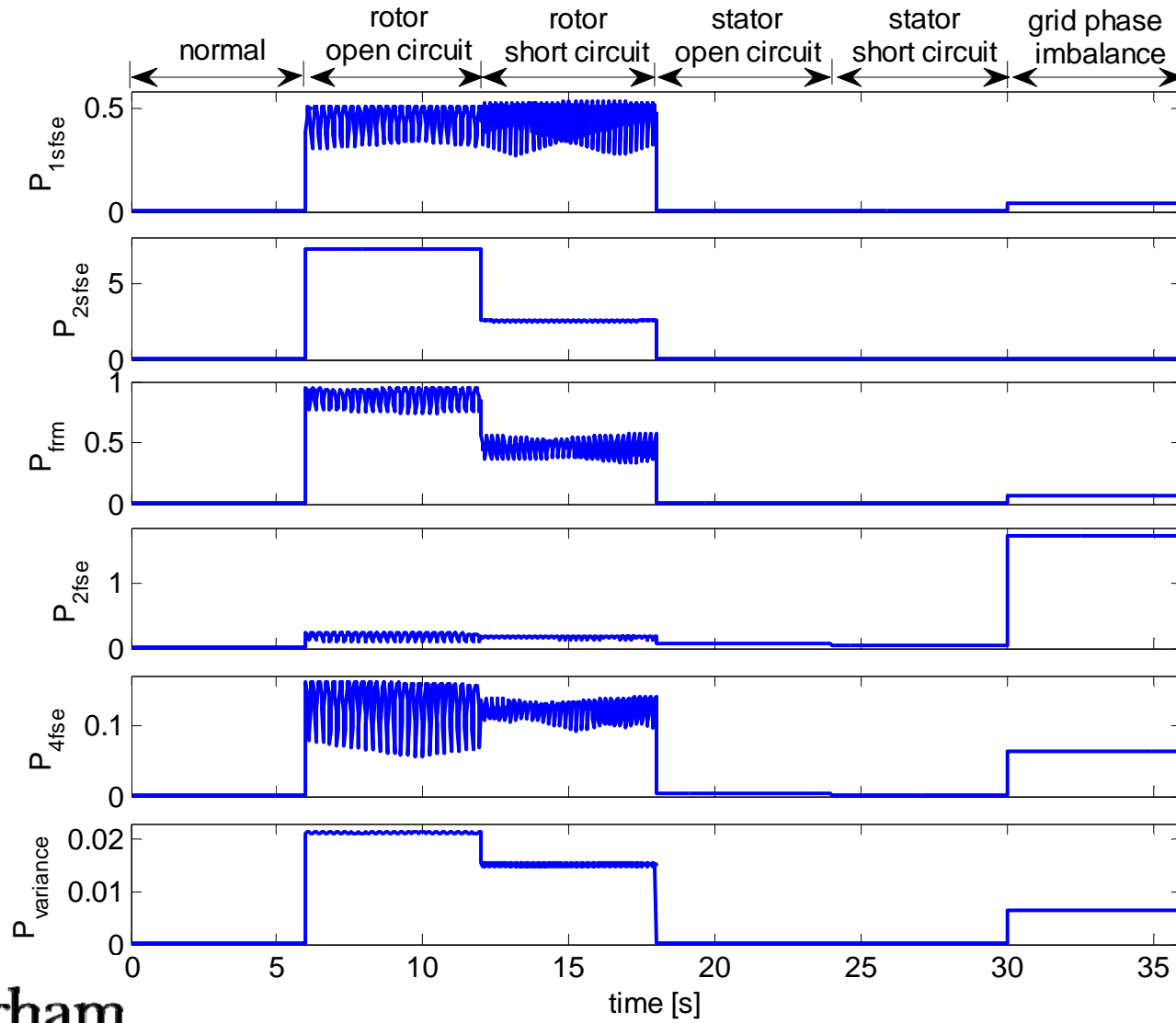

Test Rig Results – Electrical ‘Fault’

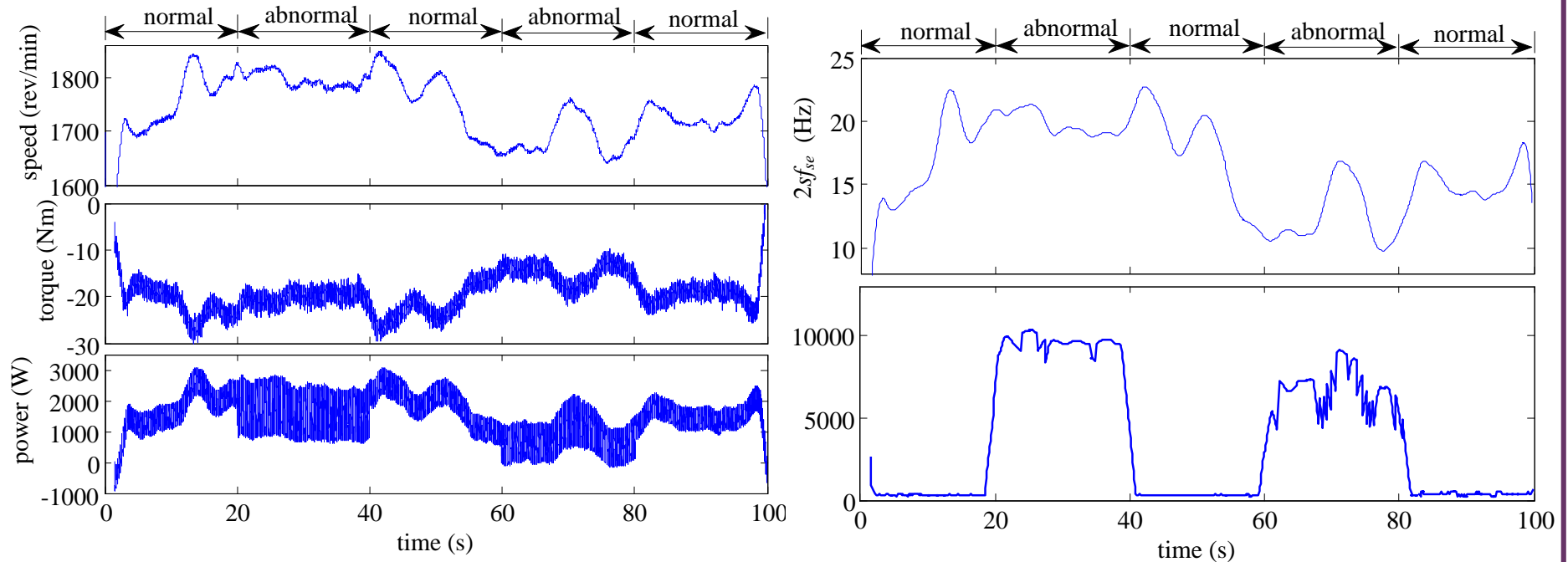

Test Rig Results – Electrical ‘Fault’

- New Technique

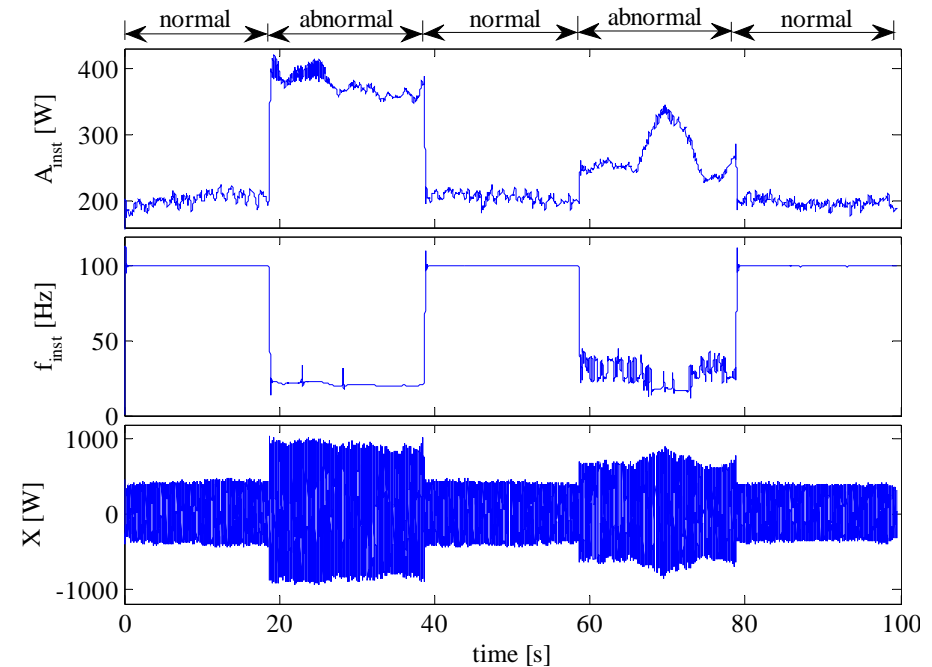
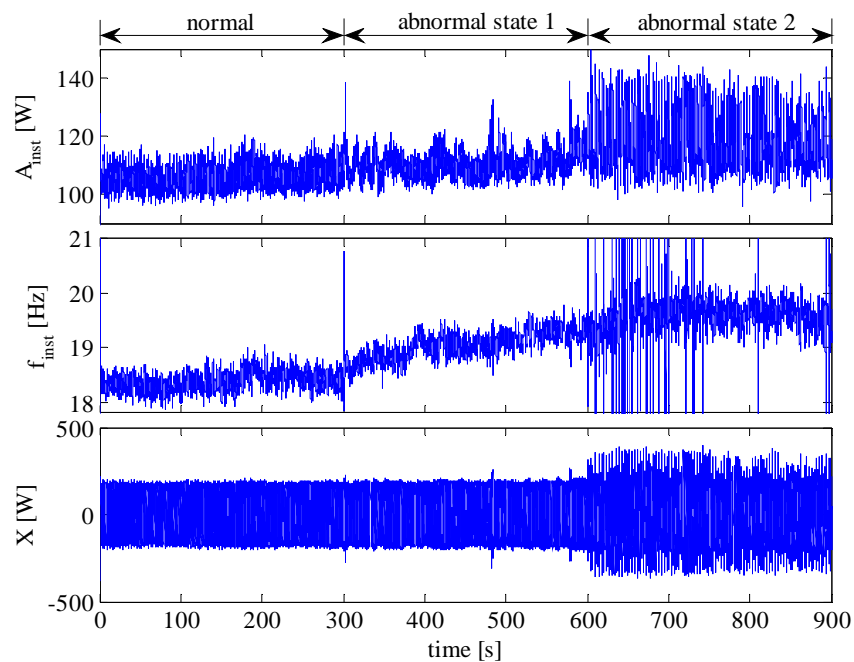

Future Investigations

- **Bearing problems**
 - (main bearing, gearbox bearings, generator bearings)
- **Damage to gears**
- **Mechanical looseness**
- **Electrical generator problems**
 - (take into account the close-loop control)

Publications to Date

- W. X. Yang, P. J. Tavner and M.R. Wilkinson, Condition Monitoring and Fault Diagnosis of a Wind Turbine Synchronous Generator Drive Train, IET Journal of Renewable Power Generation, 3(1), 2009, p1-11.
- W. X. Yang and P. J. Tavner, Empirical Mode Decomposition, an Adaptive Approach for Interpreting Shaft Vibratory Signals of Large Rotating Machinery, Journal of Sound and Vibration, In Press, 2009.
- Wenxian Yang, P. J. Tavner and Michael Wilkinson, Condition Monitoring and Fault Diagnosis of a Wind Turbine with a Synchronous Generator using Wavelet Transforms, IET Power Electronics, Machines and Drives (PEMD2008), 2-4 April, York, UK, 2008.
- Wenxian Yang, P. J. Tavner and Michael Wilkinson, Wind Turbine Condition Monitoring and Fault Diagnosis Using both Mechanical and Electrical Signatures, IEEE/ASME International Conference on Advanced Intelligent Mechatronics (AIM2008), 2-5 July, Xi'an, China, 2008.
- Wenxian Yang, P. J. Tavner, C. J. Crabtree, Research on a Simple, Cheap but Globally Effective Condition Monitoring Technique for Wind Turbines, XVIII International Conference on Electrical Machines (ICEM'08), 6-9 Sept, Vilamoura, Portugal, 2008.
- Wenxian Yang, Jiasheng Jiang, P. J. Tavner, C. J. Crabtree, Monitoring Wind Turbine Condition by the Approach of Empirical Mode Decomposition, The 11th International Conference on Electrical machines and Systems (ICEMS 2008), 17-20 Oct, Wuhan, China, 2008.
- Wenxian Yang and P. J. Tavner, Wind Turbine Condition Monitoring and Fault Diagnosis using Wavelet Transforms, the 4th PhD Seminar on Wind Energy in Europe, 1-2 Oct, Magdeburg, Germany, 2008.
- C. Crabtree and P. J. Tavner, Development Of A Test Rig For Condition Monitoring Offshore Wind Turbines, the 4th PhD Seminar on Wind Energy in Europe, 1-2 Oct, Magdeburg, Germany, 2008.
- **Further journal and conference papers have been submitted for publication**

Brief Review of Recent Achievements in Durham

Thank you for listening

Any Questions?