



Electrical Aspects of Wind Turbines

Prof Peter Tavner

Electrical Parts of the Wind Turbine



- Generator
- Converter
- Power Control
- Cables
- Transformer
- Power Collection
- Lightning Protection

1887, Cleveland, USA



- Inventor, Charles Francis Brush
- Manufactured, Cleveland USA
- Turbine Dia 17m
- 144 blades
- 10 rev/min, variable speed
- Power Output, 12kW

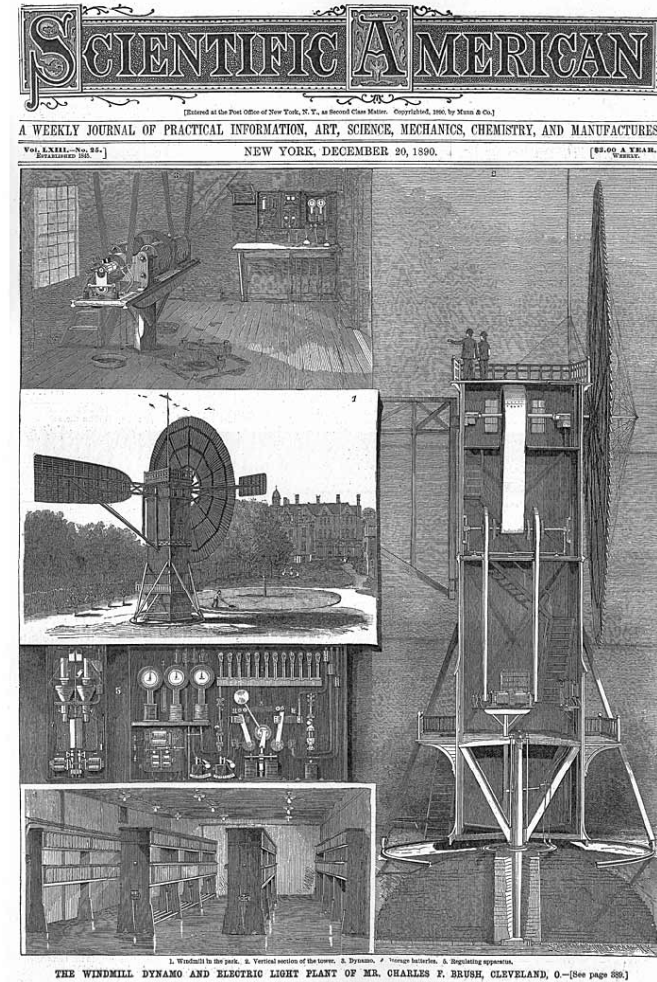

1980, California, USA



- Result of Californian environmental laws
- Small turbines <100kW
- Turbine diameters, 10-15m
- 70-80 rev/min, depending on turbine design, fixed speed
- Poorly sited
- Blade failures common
- Disastrous reliability



2003, Modern Product



- Manufacturer, DeWind
- Manufactured, Loughborough, UK
- Turbine Dia 70m
- 3 blades
- 17 rev/min, variable speed
- Power Output, 2 MW

Types of Turbine & their Control



	Speed Control	Pitch Control	Power Control	
Fixed Speed	Fixed speed/Dual speed	None	Passive stall regulation geared drive train with asynchronous generator	Geared Drive
	Fixed speed	Yes, pitch to stall	Active stall regulation geared drive train with asynchronous generator	
Variable Speed	Limited variable speed	Yes	Geared drive train with asynchronous generator control using variable rotor resistance	Direct Drive
	Variable speed	Yes	Geared drive train with slip ring asynchronous generator control using a partly rated converter	
	Variable speed	Yes	Direct drive with synchronous generator control using a fully rated converter	



Fixed Speed

Variable Speed

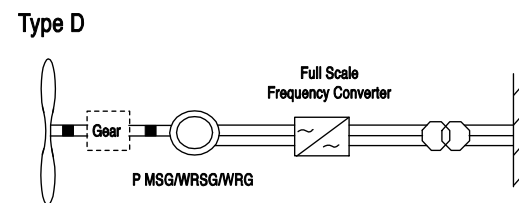
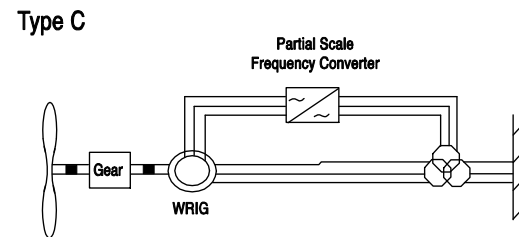
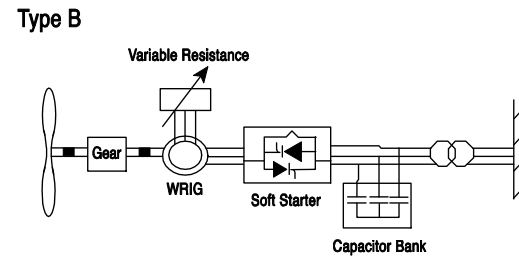
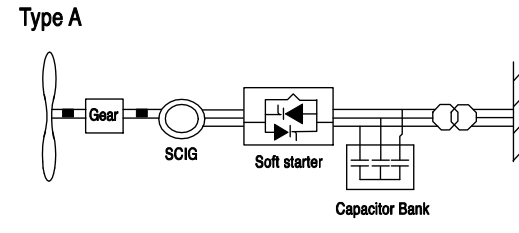

Geared Drive

Direct Drive

Types of Turbine & their Generators

Changing Technology

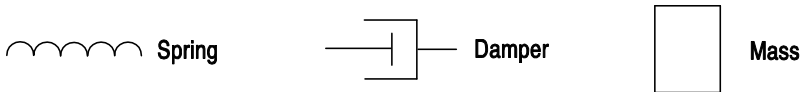
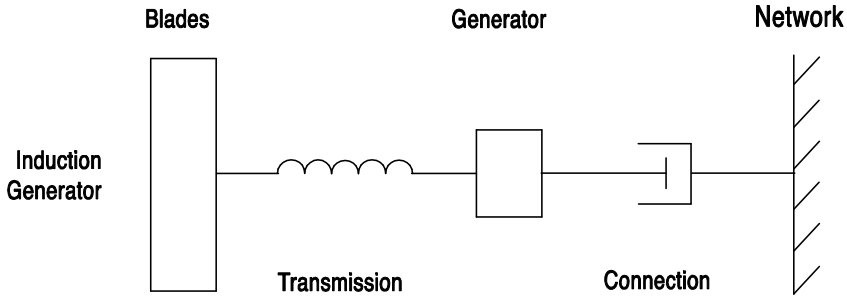
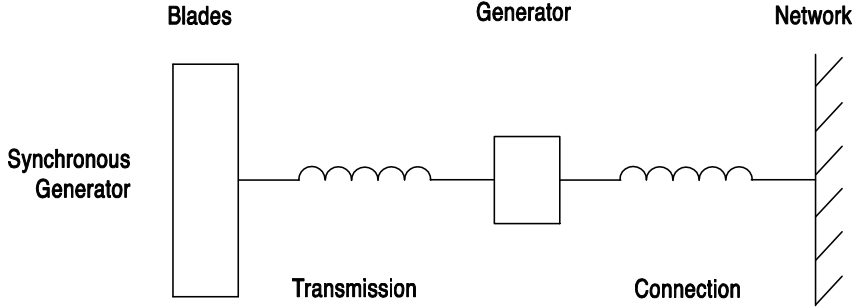

Induction Machine

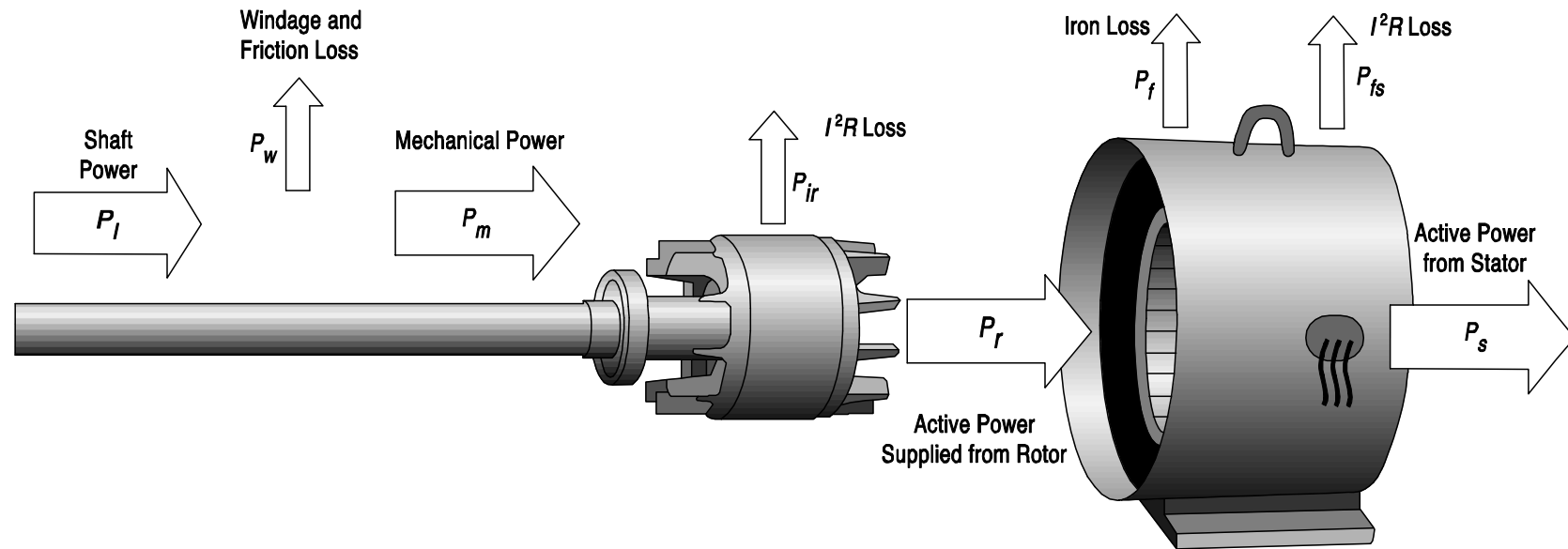

Induction Machine

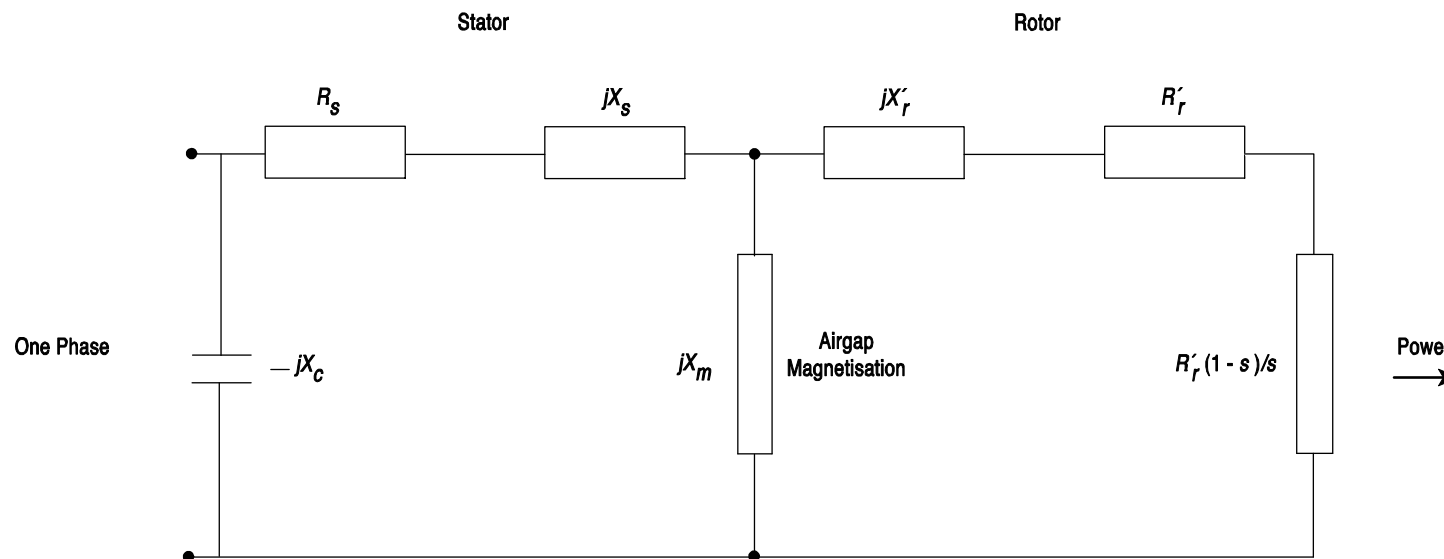

Induction Machine

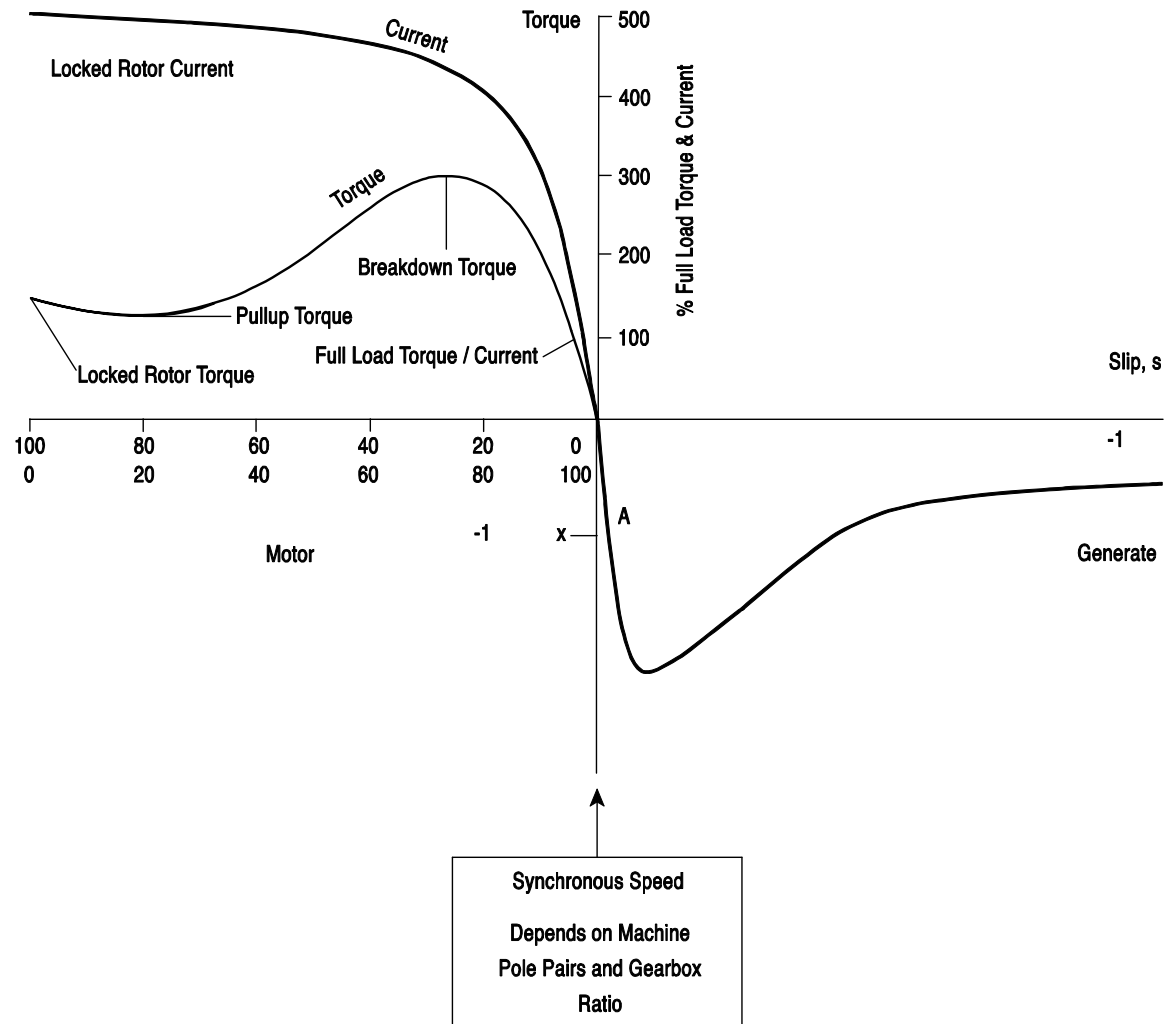

Induction Machine

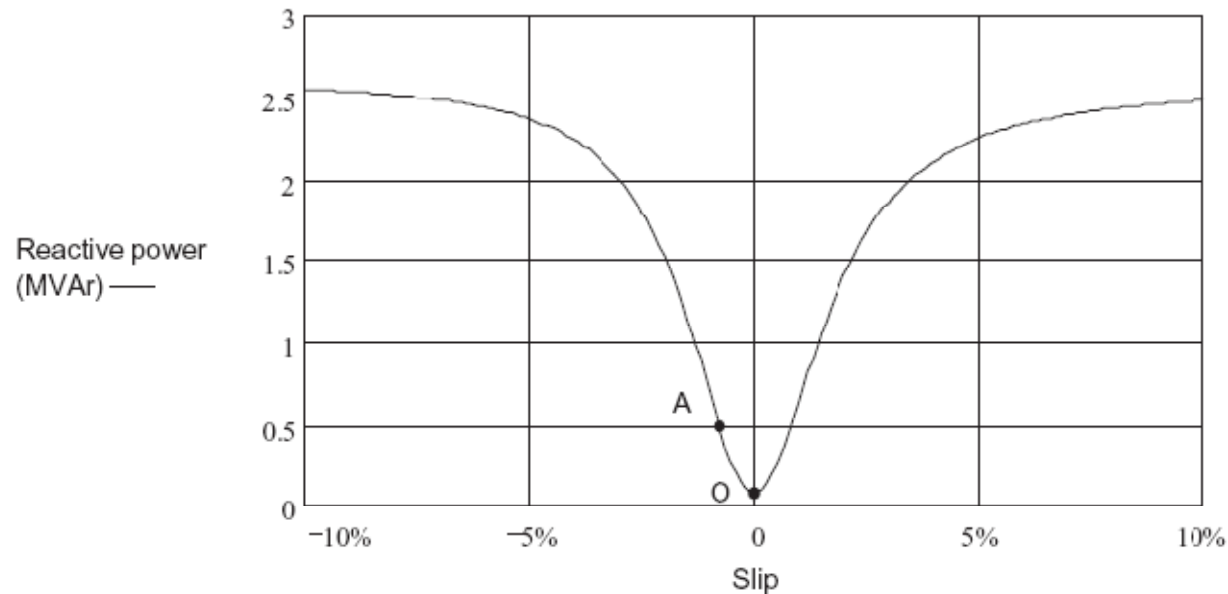
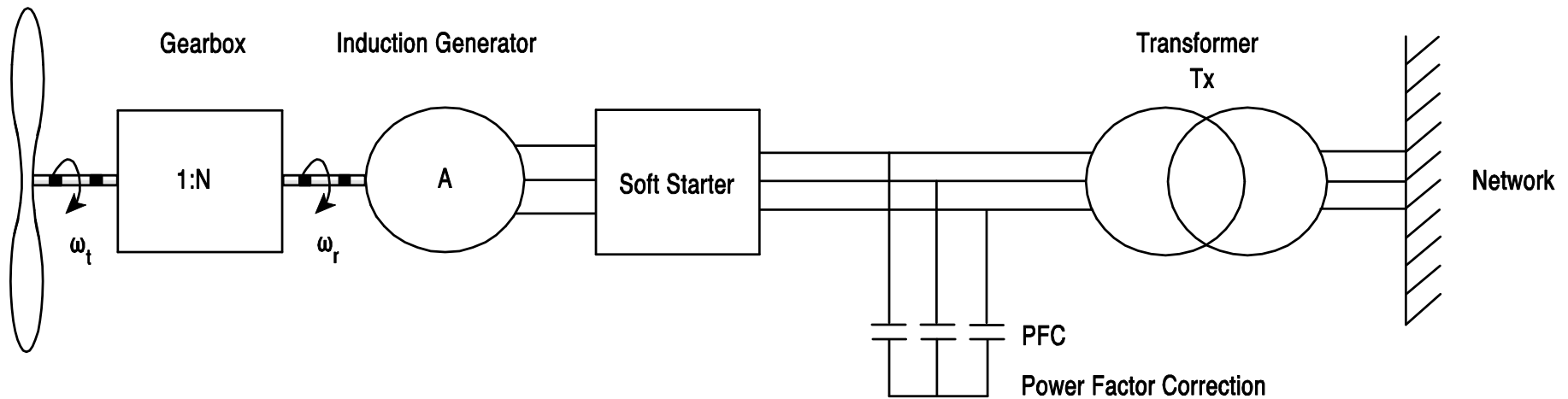

Figure 7.30 Variation of Reactive Power with Slip for a 1 MW Induction Machine

Synchronous Speed
Depends on machine
pole pairs and gearbox
ratio

Fixed Speed Turbine Induction Generator



Variable Speed Broad Speed Range

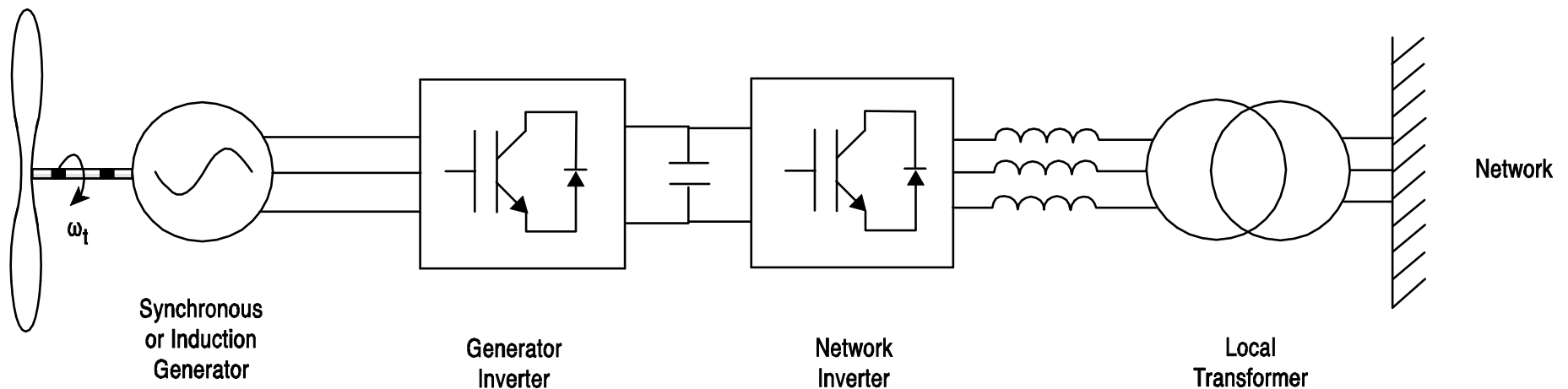

Variable Speed Narrow Speed Range

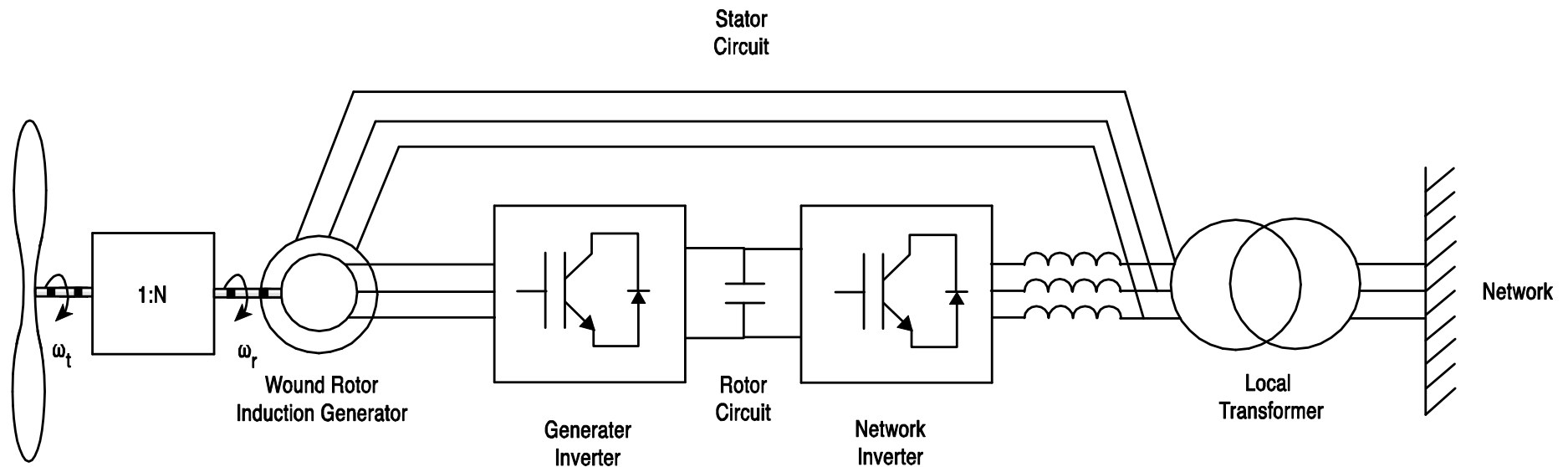

Variable Speed Turbine Converter



Variable Speed Turbine Geared Drive Induction Generator Fully Rated Converter

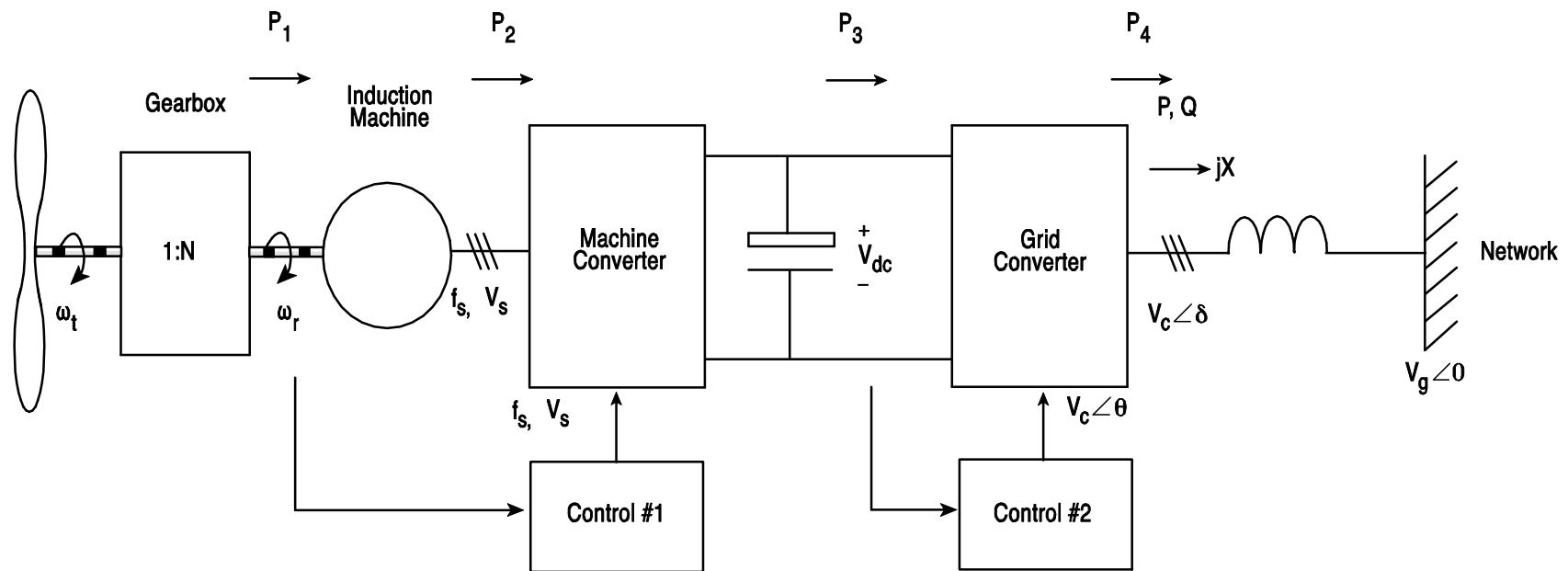

Variable Speed Turbine Induction Generator

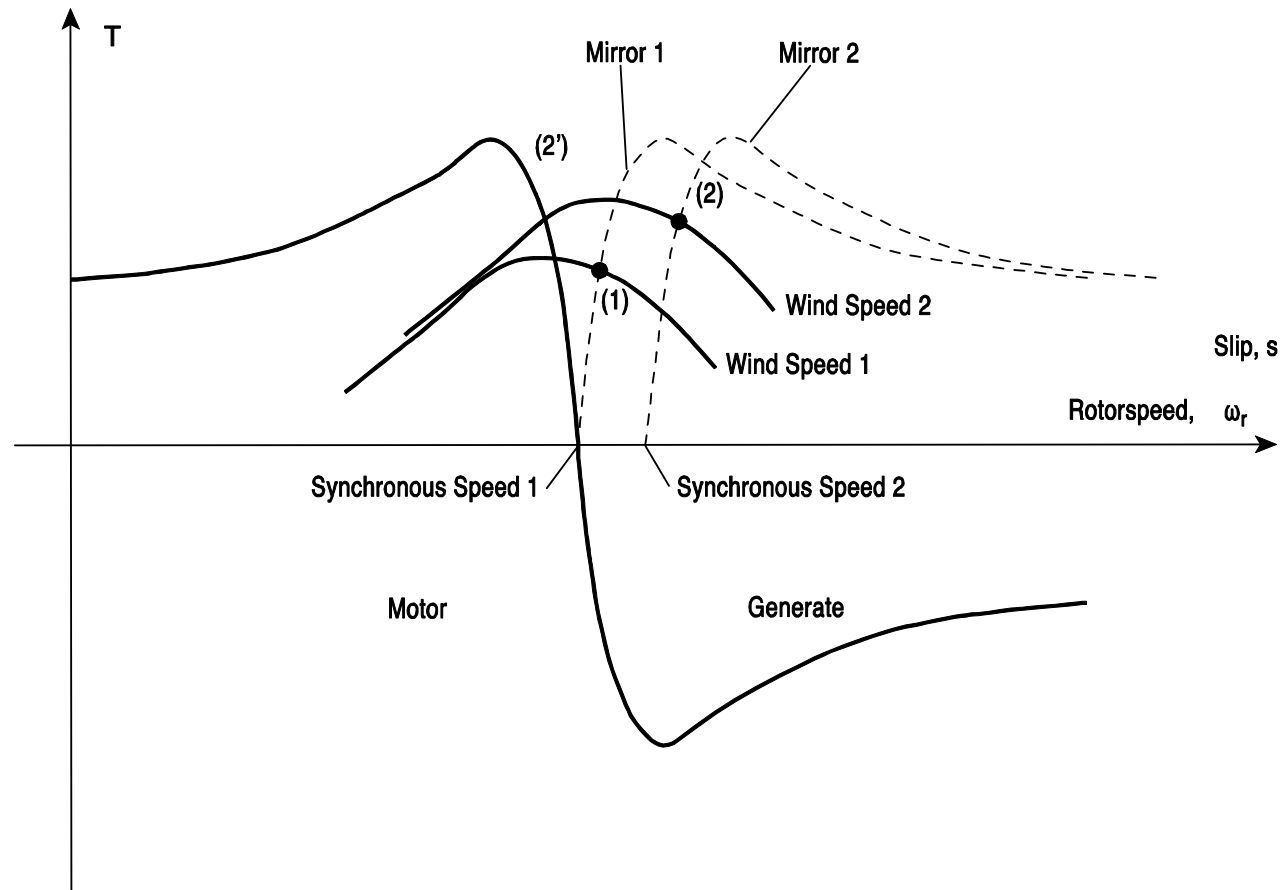

Geared Wind Turbine Induction Machine



Geared Wind Turbine Doubly Fed Induction Machine

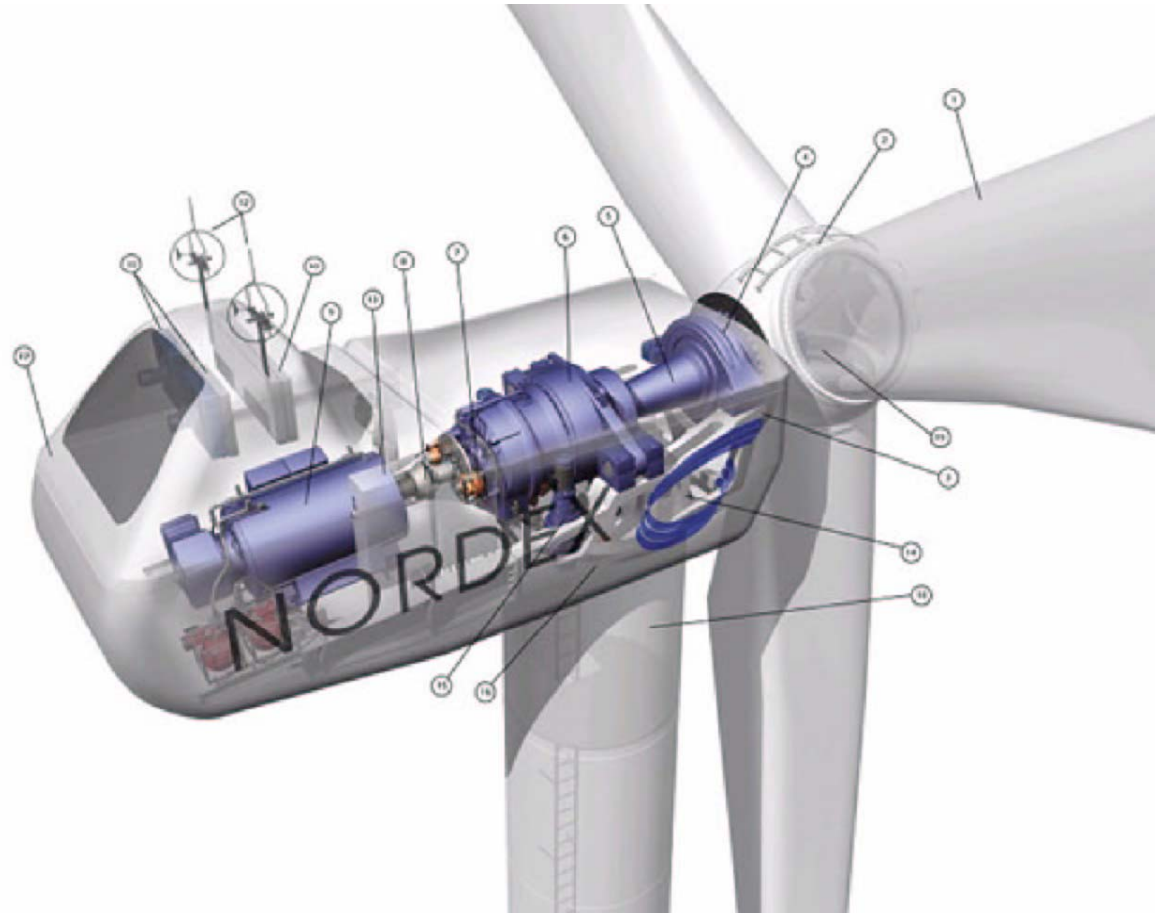

Geared Wind Turbine Doubly Fed Induction Machine



Direct Drive Wind Turbine

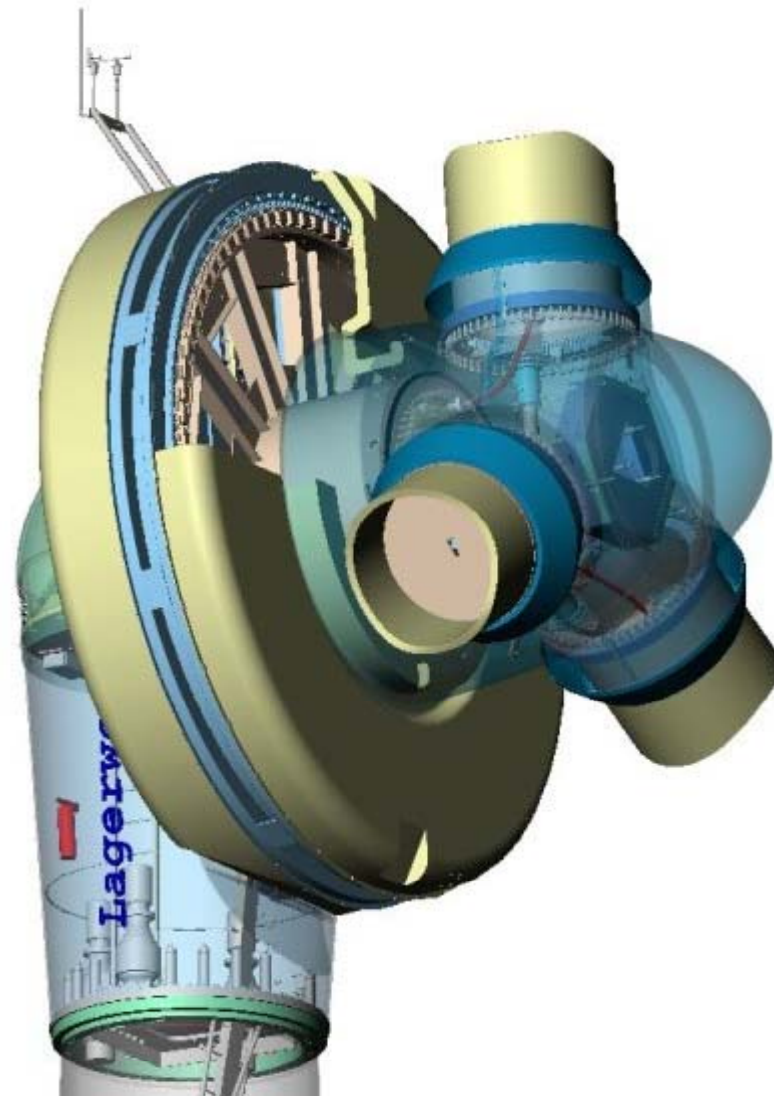

Direct Drive Wind Turbine

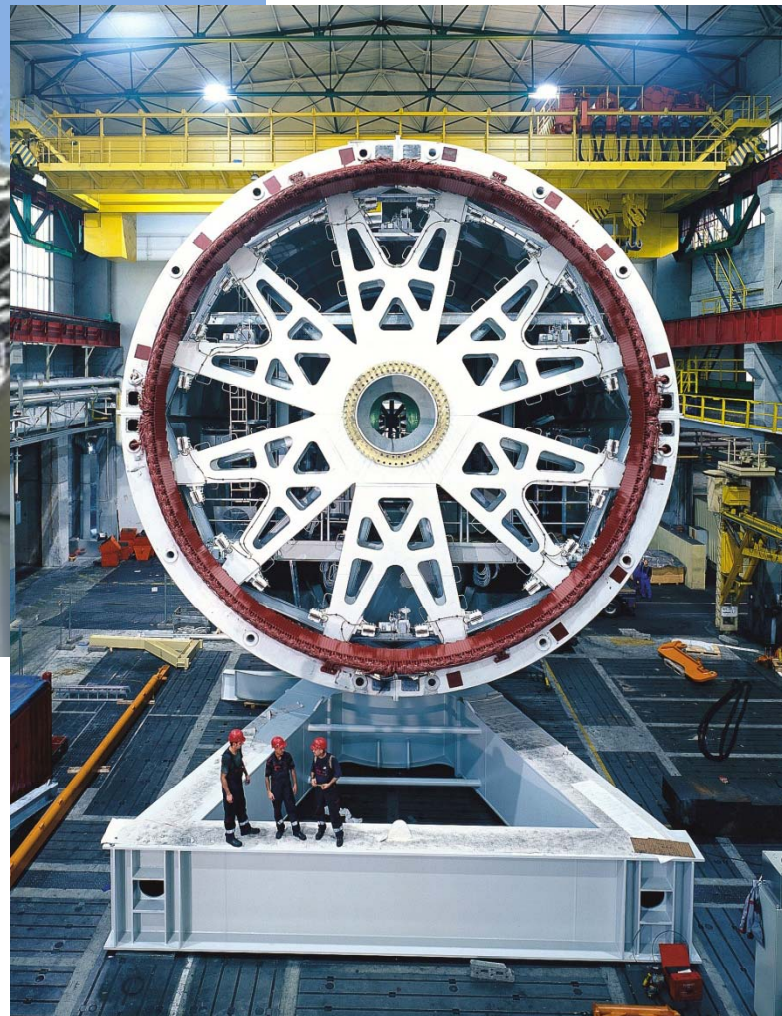

Power Collection

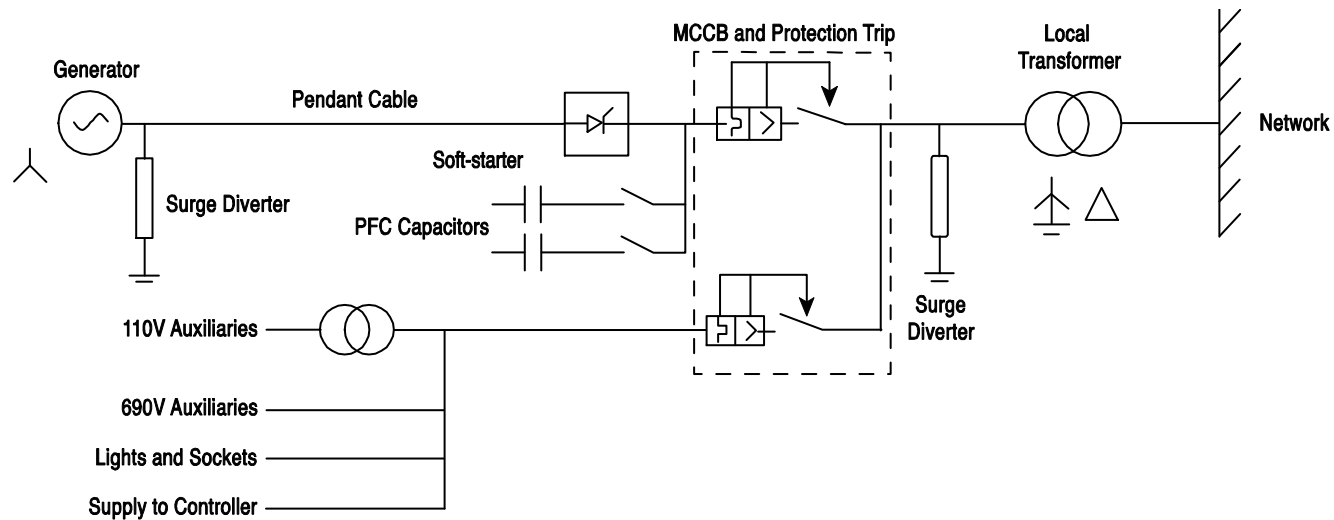

Power Collection



Figure 10.2 Transformer and Switchgear of 1.5 MW Wind Turbine, MV Switchgear on right, LV Switchgear on left (Reproduced by permission of NEG MICON; www.neg-micon.dk)

Power Collection Offshore



Maintenance Offshore



Reliability & Subassemblies, EU



European Wind Turbine Subassembly Failure Rates from 1993-2005

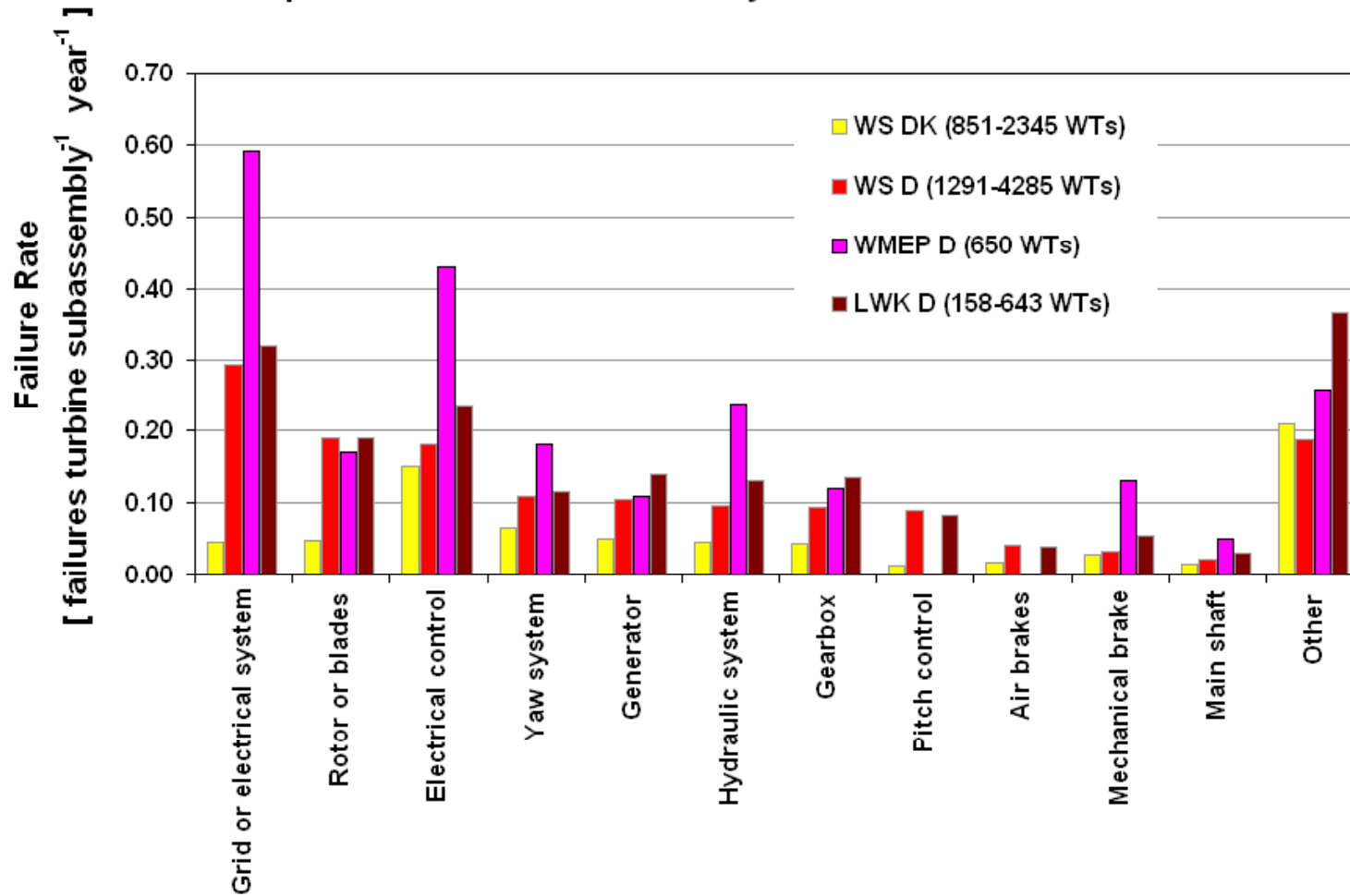



Thank you

- A. D. Hansen and L. H. Hansen. Wind turbine concept market penetration over 10 years (1995-2004). *Wind Energy*, **10**(1), 2007.
- T Burton, D Sharpe, N Jenkins, E Bossanyi, *Wind Energy Handbook*, John Wiley, 2001.
- W. E. Leithead, Prospects for wind energy, *Phil. Trans. Royal Society A*, **365**(1835), pp. 957- 970, 2007.
- P. J. Tavner, J. P. Xiang, and F. Spinato. Reliability analysis for wind turbines. *Wind Energy*, **10**(1), 2007.