

# Lightning Protection of Wind Turbines – A Comparison Of Real Lightning Strike Data And Finite Element Lightning Attachment Analysis

Vidyadhar Peesapati and Ian Cotton, *Senior Member, IEEE*

**Abstract**--Wind turbine lightning protection systems have been developed to the point where lightning damage is relatively rare. However, with windfarms moving offshore, manufacturers are striving to continuously improve lightning protection systems while ensuring that they comply with relevant IEC standards. The case of offshore wind farms is particularly important due to the difficulties faced in accessing a wind turbine should this be required owing to lightning damage. The paper details work done to model upward propagating lightning strike attachment on a wind turbine. A 3D electrostatic model of a full scale wind turbine has been modelled using available Finite Element Analysis software. This full scale model is subjected to high electric fields comparable to those created by a charged cloud. Results from these simulations are then compared with those found from analysis of real lightning strike data taken from wind turbines and windfarms across the world.

**Index Terms**--Lightning, wind turbine, finite element, modeling, electric field.

## I. INTRODUCTION

Wind turbines being developed offshore are increasing in size and this trend is not likely to abate in the near future. The lightning strike frequency to onshore wind turbines is usually calculated based on the likelihood of downward lightning attachment. However, taller wind turbines such as those being used offshore will be increasingly subject to upward lightning attachment. This form of a lightning (to be discussed in more detail in a later section) is triggered by the wind turbine itself in the presence of a thundercloud and has the ability to significantly increase the number of lightning strikes to a wind turbine per year. As the attachment processes are fundamentally different to those of downward lightning,

there is also uncertainty regarding the likely point of lightning attachment. Current turbine lightning protection systems have been shown reasonably effective for downward lightning but there is an underlying risk in assuming the same systems will work for upward lightning.

This paper aims to examine the likely points on a wind turbine structure where upward propagating lightning may form. It also compares these results with real lightning strike data, to see if the results correlate. In the introduction, a background of the problems wind turbines face from lightning is given and the phenomenology of lightning is more fully described. Later sections introduce the finite element models used in this work and the corresponding results.

## II. CHARACTERISTICS OF LIGHTNING

Lightning is an atmospheric discharge of current. The highest recorded value of lightning current is around 250kA [1][2]. However, this value is very rarely seen, the median (for a downward negative stroke) being about 30kA with the median values of charge transfer and specific energy being 5.2C and 55kJ/Ω respectively [1][2]. The visible part of the lightning strike process, whether lightning strikes the ground or not, is termed as a “lightning flash”. The individual components of this lightning flash are defined as strokes. Lightning can be classified into two main types with respect to wind turbines, upward and downward initiated. These are also known by the names, cloud-to-ground and ground-to-cloud lightning. These two forms of lightning can be further subdivided into positive and negative polarity respectively, the polarity being that of the charge transferred from the cloud to the ground.

### A. Downward Initiated Lightning

Downward initiated lightning starts from the cloud with a stepped leader moving towards the earth. The end of the leader, the leader tip, is in excess of 10MV with respect to the earth [3]. As the tip descends, it raises the electric field strength at the surface of the earth. Where this field is elevated significantly, typically around sharp and/or tall objects, local ionization of the air takes place and answering leaders are emitted and travel towards the downward propagating leader.

---

This work has been carried out under the Supergen V Wind Energy Theme, funded by the Engineering and Physical Sciences Research Council, UK. Further information about Supergen Wind is available at <http://www.supergen-wind.org.uk/>

V Peesapati is with the Department of Electrical and Electronics Engineering, Power Systems Group, University of Manchester (e-mail: vidyadhar.peesapati-2@postgrad.manchester.ac.uk)

I Cotton is with the Department of Electrical and Electronics Engineering, Power Systems Group, University of Manchester (e-mail: ian.cotton@manchester.ac.uk).

When an answering leader and stepped leader meet, this completes the channel or path from the cloud to earth, thus allowing the charge in the cloud to travel through the ionised channel. The location from which these answering leaders form is critical in determining which point of the wind turbine will be hit by lightning. The first transfer of significant current is the first return stroke, which has a peak value of upto a few hundred kiloamps and a typical duration of a few hundred microseconds. After a certain time interval, further strokes may follow the already ionised path, these are known as subsequent return strokes (Fig 1). On average, a negative downward lightning flash may contain 2 to 3 subsequent return strokes. Positive downward flashes (only 10% of those observed worldwide) are higher in magnitude but typically contain no subsequent strokes.

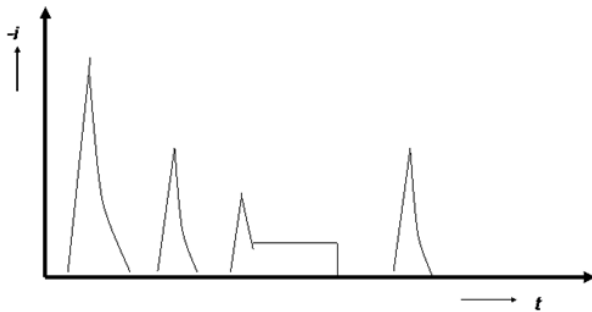

Fig. 1. Profile Downward Initiated Lightning

### B. Upward Initiated Lightning

The presence of tall structures and objects brings rise to another form of lightning, which is upward initiated. Tall structures enhance the electric field produced by a thundercloud and this can give rise to upward propagating leaders that move towards the cloud and which can then develop into a lightning flash. The attachment process is therefore somewhat different to downward propagating lightning and this issue will be dealt with in a later section. This phenomenon is particularly common where the cloud height is quite low (often during winter months in coastal areas or in mountainous regions). The profile of an upward discharge is different as compared to that of a downward initiated discharge (Fig 2).

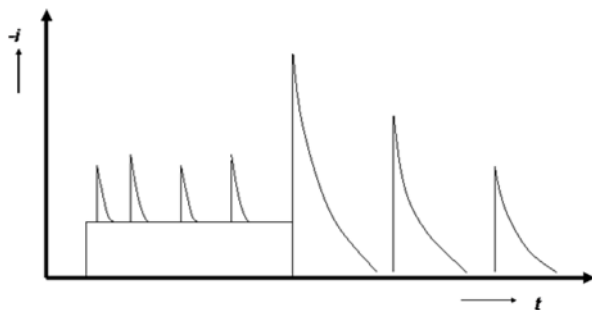

Fig. 2. Profile Upward Initiated Lightning

An upward initiated discharge often starts with a continuing current on which may be superimposed short duration high magnitude current pulses. Although the current values are quite low at around 10kA [3] as compared to downward lightning, the charge transfer associated with the continuing current phase can be quite high. The initial continuing current may be followed by a number of return strokes that are similar to those observed in a negative downward lightning flash.

### III. LIGHTNING AND WIND TURBINES

The high peak currents carried by lightning strikes are a source of significant energy. If the wind turbine lightning protection system does not divert this lightning current safely to ground through a low impedance path, significant damage can result. If a component of a wind turbine is damaged there are two things that need to be considered; the resulting repair costs and the associated loss in production caused due to downtime. Given the move of wind turbines to offshore locations and the need to mobilise special floating cranes, these costs and repair times will only have increased in recent years. Due to the risk of damage and possible downtime due to lightning strikes, all new wind turbines are normally equipped with lightning protection systems. Guidance on how to achieve this is given in [4].

The main functions of the lightning protection installed on a wind turbine are:

- Successful attachment/formation of the lightning strike to a preferred attachment point such as the air termination system on the blade
- Facilitating the passage of the lightning current through the system into the earth without causing damage to systems including that damage that would result from high levels of electric and magnetic field
- Minimising the levels of voltages and voltage gradients observed in and around the wind turbine

These functions can be achieved by a number of different methods which have changed and improved with the development of new wind turbines. As they are the highest part of the turbine and therefore particularly prone to lightning attachment, the blades are usually considered an extremely important part of the wind turbine in terms of lightning protection. The different types of lightning protection installed in wind turbine blades are [3]:

- Air termination systems on the blade surfaces
- High resistive tapes and diverters
- Down conductors placed inside the blade
- Conducting materials for the blade surface

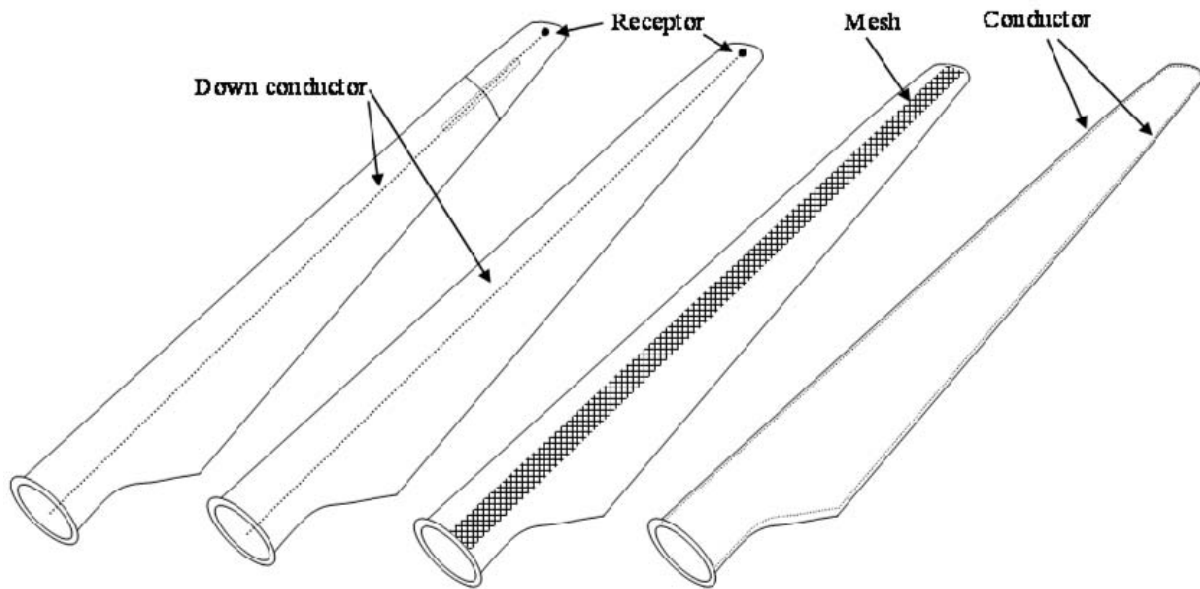

Fig. 3. Lightning Protection Methods for Rotor Blades

In all types of LPS, the metallic air terminations, strips and diverters and down conductors should be of sufficient cross sections that they safely conduct the lightning current without any physical damage.

A system that is widely used is the internal lightning protection system consisting of a internal lightning down conductor capable of carrying the lightning current. Metal receptors (Fig 3) which act as air terminations penetrate the blade surface and are then connected to the down conductor. This system of external receptors connected to an internal down conductor is being widely used for blades upto 60m [3] and the system is not likely to change for blades of larger lengths.

According to [8], rotor blades with built in lightning protection are far less likely to experience extensive damage as compared to those without. Current lightning protection systems for rotor blades are designed to withstand 98% of lightning strikes [5] but there is still a risk of damage, particularly at the attachment point. More information regarding the types of lightning damage that have been observed in wind turbines and the types lab tests that can be used to verify/understand lightning protection performance is available in [4] [5] [9].

#### IV. LIGHTNING DATA SOURCES

The lightning data used in this paper comes from an Offshore Windfarm. The data has been collected over a period of over three years, the oldest lightning strike record being in June 2003 with the last reading analysed being from in October 2006. This is an equivalent of 216 turbine years.

Data at this windfarm is collected in two ways. The first measurement system is the active Jomitek system. This

consists of two antennas which are placed on opposite sides of the tower [10] [11]. In the event of a lightning strike to the wind turbine, the lightning current flow induces a voltage into the antennae system as a result of the rate of change of magnetic field around the tower. Lightning strikes away from the wind turbine are discriminated against by adding the outputs of the antennae together. The Jomitek system has a simple analog trigger level which at the offshore wind farm is set to 1 kA peak. The output of this measurement system is connected to the turbine SCADA system. In the event of the system being triggered, an alarm is raised but no data regarding the possible magnitude of the lightning current is obtained. For this reason, peak current sensor (PCS) cards manufactured by OBO Bettermann are placed on the down-conductor of each of the blades and of the air terminals protecting the aviation lights and the wind-vane. These cards have a magnetic strip imprinted with a pre-defined signal. When placed near a down conductor, the magnetic field resulting from the flow of lightning current erases a portion of this magnetic strip and by the use of a card reader, the current that the card has observed can be found. Once the Jomitek system has been triggered, it is possible to go to the wind turbine to remove the PCS cards and therefore gain knowledge of the lightning strike magnitude along with the component struck. The PCS cards are capable of only recording one peak current (the highest observed). During multiple strikes it is not possible to determine the number of strikes. Also the PCS cards have a range of 3-120 kA. Peak currents lower than 3 kA are not registered and peak currents above 120 will register 120kA.

The data from the offshore windfarm is firstly examined by showing the components of the wind turbine on which the PCS cards indicated current readings following an alarm. Multiple registrations were present on a number of occasions.

The data in Fig 4 shows that the wind vane and aviation lights PCS cards (actually fitted onto the lightning protection rods of these components) indicated lightning current flowing through these components regularly. This result is in contrast to the work by a number of other researchers who suggest that the blades are the parts of a wind turbine that are most likely to be hit by lightning [3] [5] [8] [12] [13]. However as most wind turbines are not equipped with PCS cards and those which are have them mainly fitted in the blades, there are for most wind turbines simply no effective registration of lightning striking elsewhere but the blades. From Fig 4, there is likelihood of increased lightning strikes to the windvane. The increase in the number of strikes to the windvane could be explained by an increase in upward lightning (as will be demonstrated by the attachment modelling in the next section). The hypothesis of upward lightning being a major contributor to the lightning strike rate is strengthened when the distribution of lightning strikes by month is examined. The data shown in Fig. 5 gives

the peak current read from the each PCS cards due to an event detected by the active alarm system by date. In total, 33 out of 51 lightning events occurred during the winter months. This shows that winter lightning is a significant phenomena even in the country where the windfarm is installed, which is not particularly prone to winter lightning.

In other areas prone to winter lightning, the following has been shown through observations of lightning activity to towers:

- The incidence of lightning strikes to tall structures during winter is greater relative to that during summer [15].

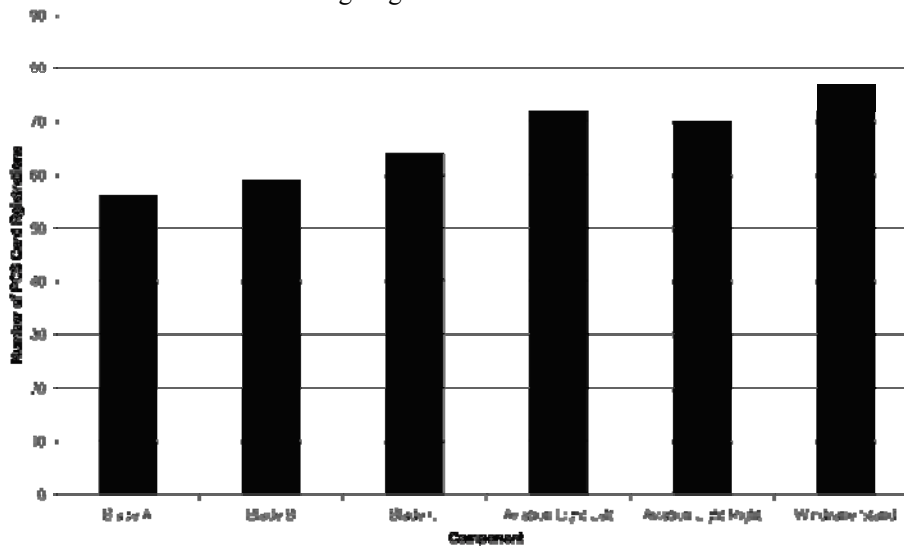

Fig. 4. Number of PCS Cards Showing a Lightning Current Reading Following an Alarm Even

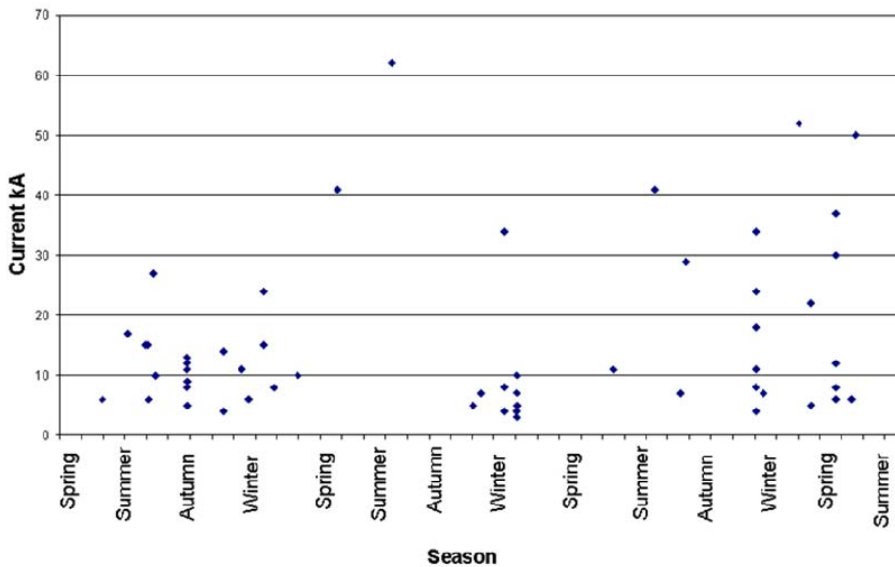

Fig. 5. Lightning Strikes Given By Their Peak Current versus Season of Occurrence

- A large percentage of these lightning strikes, up to 98% are upward propagating (it is noted that any significantly tall structure in any season is likely to receive mainly upward propagating lightning). Even on flat terrain and for objects of moderate height, there is a large number of upward strikes [15][16].
- Winter lightning simultaneously strikes more than one tower within a lightning flash. The probability of occurrence of these simultaneous strokes to multiple points was up to 20% in the studies detailed in [16].

The data that has been presented matches with the findings of the first bullet point, i.e. more lightning in winter than summer. The second bullet deals with the number of upward lightning strikes.

## V. FEA MODELLING OF A CLOUD AND WIND TURBINE

FEA Modelling of lightning attachment to wind turbines has been carried out by other researchers, [14] [17] [18] being examples of some of the work carried out. However, with few exceptions, most of these models were focused on downward propagating lightning and therefore involved the modelling of a stepped leader to examine the resultant electric field environment on/around the wind turbine. One example where upward propagating lightning is considered is [14] where the authors have looked specifically at upward propagating lightning in terms of comparing the likely lightning attachment points when the blades are in motion and when they are stopped. The authors analyze the electric field enhancement for different angular positions of the blades when they are stationary. It was concluded in this paper that the wind turbine was prone to higher field enhancement and that leaders would form in more locations when the blades are in motion. It was advised that the halting of the blade movement therefore reduces the risk of lightning strike attachment.

From the lightning strike data that has been analysed in the previous section, it can be seen that upward initiated lightning might contribute to a large portion of the lightning strikes that attach to a wind turbine. Thus while evaluating likely attachment points from a wind turbine in this paper, only upward lightning is taken into consideration. In comparison to previous wind turbine models [14] [17], the model used includes the windvane at the back of the nacelle and the risk of lightning attachment to the same is analysed along side with the blades.

### A. The Cloud Model

The models that are usually used to replicate the electric fields found under a thundercloud consist of a vertical tri-pole made from two positive charges and a negative charge. A summary of various models that have been produced can be found in [15]. The cloud model that has been simulated here is taken from this source and consists of three point charges suspended in air at different heights from the ground. In the simulation, the ground has been modeled as a perfect conductor. The three

charges of 3C, -40C and +40C are placed at heights of 2, 7 and 12 km from the ground respectively. The charges are modeled as spheres of radii 900m for the 40C charges and 150m for the 3C charge. The size of the spheres is picked in such a way that when the meshing process takes place, the electric fields in the area of interest within the model are accurate. The model is shown in Fig 6.

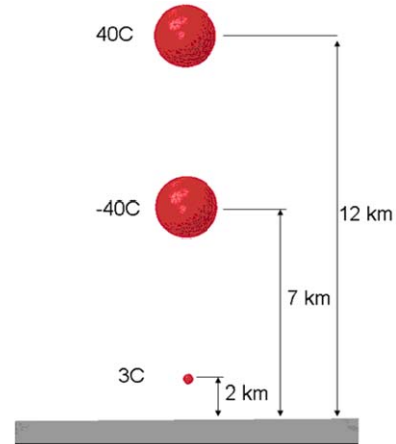

Fig. 6. Cloud Model (charge sizes not to scale)

Fig 7 gives the vertical component of the electric field at the ground due to this vertical tri-pole. This plot agrees with that shown in literature [15] and has a maximum ambient field of just over 5kV/m (the E component in the graph must be scaled by a factor of 1000 owing to the operation of the model). According to the convention adopted in electrostatic field analysis software, a downward directed field is taken to be positive in polarity [15].

### B. The Wind Turbine and Blade Model

The model used in the simulations is based on a 2MW present day wind turbine. The blade model used in the simulations presented is 40 meters long and is a simplification of a real blade in that it is taken to be made entirely of fibre glass with a relative permittivity of 4. The chord length of the airfoil used for designing the blade is 2.75m, the chamber length (upper + lower) is 0.9m, and a thickness of 10cm is maintained throughout the blade. Due to the complicated shape and difficulty of meshing, these dimensions are maintained along most of the length of the model, although several aerofoil profiles are normally used in real blades. The chord length decreases from 3.5 meters at the blade root to a thickness of less than 5mm at the blade tip.

Integrated into the blade design is the lightning protection system, in this case an internal downconductor with tip receptors. The tip receptor is placed 2.5 meters from the tip of the blade (37.5 meters from the root of the blade) and the remaining two receptors are placed evenly along the length of the blade. The tip receptor is usually a lot closer to the tip of the blade, but due to meshing difficulties in the FEA software, the position has been changed further down the blade. The receptors are 10mm in diameter and are connected to a down conductor that runs inside the hollow blade. The diameter of

the down conductor is set to 10mm. The down conductor and the receptors are made of copper.

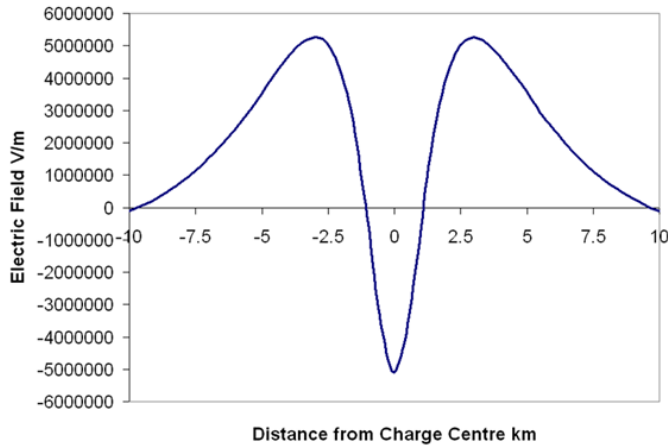

Fig. 7. Electric Field ( $E_y$ ) Plot above Ground

The wind turbine tower and nacelle are conductive and are set to ground potential. The height from the bottom of the tower to the centre of the hub is approximately 70m (Fig 8). The nacelle is 6m long, 4.5m wide and 6m high. The wind instruments are placed at the rear of the nacelle. Wind instruments on the windvane are protected from lightning using lightning rods. The lightning rods protecting the wind instrument end in a hemispherical tip with a radius of curvature of 0.02m.

### C. Modelling Of Lightning Attachment

In both upward and downward propagating lightning, the formation of upward propagating leaders from the wind turbine is critical in terms of defining the location on the structure that will be struck. For downward propagating lightning, the downward stepped leader provides a non-uniform electric field in the air around the wind turbine. This high electric field, when intensified by elements of the wind turbine lightning protection system, will allow the formation of upward propagating leaders should specific conditions be met.

For upward propagating lightning, the mechanism for the formation of upward propagating leaders is nearly identical but in this case the electric field in the air is near uniform being generated by the cloud and not by a stepped leader.

This means that the strong influence of the stepped leader position is removed from the consideration of upward leader formation and it is likely that the likelihood of formation will be dominated by the geometry of the wind turbine structure itself.

To consider this issue further, it is important to consider the conditions necessary for the propagation of a leader. These are as follows and have been used in other papers relating to upward / downward lightning (even though these conditions have been derived from laboratory experiments for the streamer inception from Franklin rods) [19]:

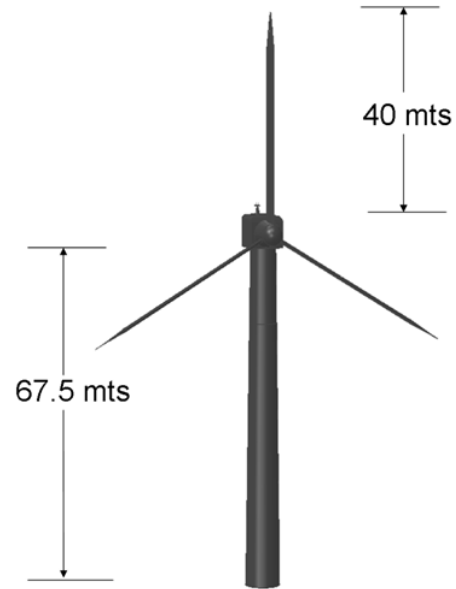

Fig. 8. Wind Turbine Model

**Condition (i):** The inception of a streamer discharge at the tip of the object by the creation of an electric field in the order of 3MV/m

**Condition (ii):** The availability of the critical background field necessary for the transition of a streamer into a leader and the stable propagation of that leader (the magnitude of this critical background field depending on the height of the structure)

Equation (1) is used in determining the required background field necessary for the propagation of the leader. According to [16] (a simplified theory of Lalonde's theory), for stable propagation of the leader, the atmospheric electric field  $E_{atm}$  must be greater than the minimum value required for stable propagation of the leader  $E_{stab}$  which is given by the following:

$$E_{stab}(H) = \left[ \frac{240}{1 + \frac{H}{10}} + 12 \right] \cdot \delta, \text{ with } \delta \approx 1 \quad (1)$$

Where H, is the height of the structure.

It must be noted that though these are the conditions required for the successful attachment, they do not need to be fulfilled in the same order. For example, the background field might be enough for the streamers to develop into leaders, before the inception of streamers itself. Also, if one condition is fulfilled it is not necessarily the case that the other is readily available. For example, a streamer might not develop into a leader if the background field necessary for the propagation is not available. In such a case, according to [19], the streamers will

be incepted again and again until there is enough background field for them to develop into leaders.

#### D. Upward Lightning Initiation locations

The model of a wind turbine must be combined with information from the cloud model in the finite element analysis software to allow analysis of the likely points of upward lightning formation. The electric field applied in the model is a uniform produced by a plane electrode located 200m above the ground. The magnitude of the applied electric field is based on the results found from Malan's charged cloud model in the FEA simulations already described. When the wind turbine is inserted into this electric field, field enhancement is seen at certain locations of the wind turbine. As is shown in Fig 9 and 10, the level of electric field intensification is particularly high around the lightning protection system of the wind instruments and at the blade tip receptor.

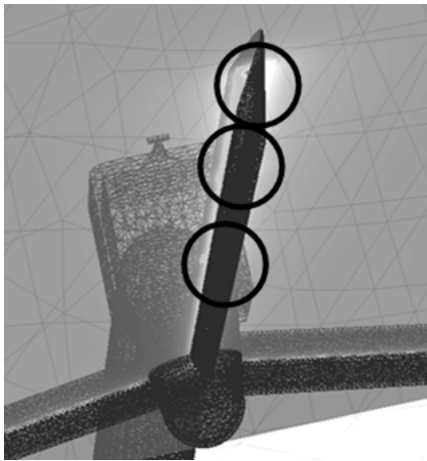

Fig. 9. Field Enhancement around the blade receptors (the locations of the receptors are circles). Light areas indicate high electric fields.

The results from the FEA simulation show a high probability of upward streamer inception from the blades and the wind vane. The production of upward initiated lightning initially depends on a given level of electric field enhancement existing around a component such as the windvane / blade and also their position [14]. These results coincide with those found from analysing the lightning strike data of the offshore windfarm. The actual lightning strike data presented in Fig 4 showed that the windvane at the back is as vulnerable to lightning attachment as the blades. This correlates with the results from the model which showed significant enhancement on the lightning protection system of the wind instruments.

The impact of cloud height on ambient electric fields above ground can be assessed using the FEA model of the thunderstorm cloud (Fig 7).

The x-axis of this Fig 11 refers to the height of the lowest 3C charge (Fig 7). The ambient electric field above ground dramatically increases as the cloud height is lowered as the relative separation of the tripole charges become significant in comparison with the distance to ground. Fig 11 indirectly

relates to the risk of higher frequency of lightning strikes during winter. Winter cloud height is lower as compared to that in summer. According to [20], the charge distribution in winter thunderclouds is different. The authors highlight the different vertical extensions of the clouds and the different temperatures change the position of the charge centers.

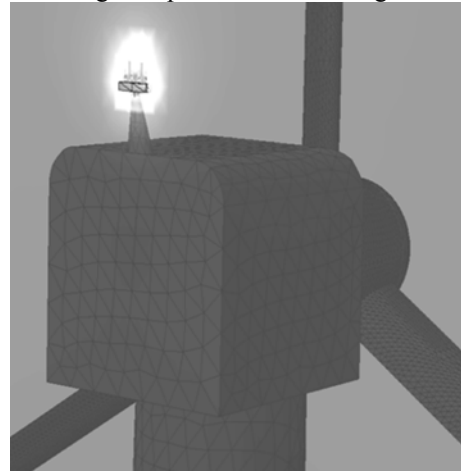

Fig. 10. Field Enhancement around the Windvane

Fig 11 shows the increase in the electric field 200 meters above ground due the lowering of the cloud charges in 100m steps.

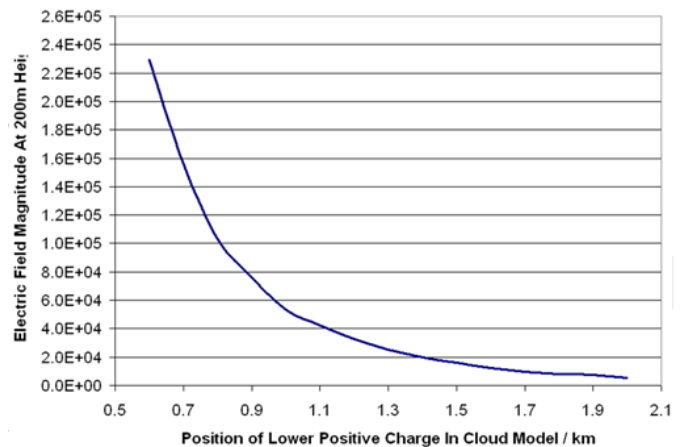

Fig. 11. Changes in Electric Field Due to Lowering of Charges

Winter clouds over the North Sea have a stronger vertical field in the lower atmosphere [20]. A large number of lightning strikes on wind turbines are usually experienced during winter [9]. The move of wind farms to offshore sites and the low cloud height in winter would seem likely to increase the risk of upward lightning in the case of wind turbines. The hypothesis of upward lightning being a major contributor to the lightning strike rate is strengthened when the distribution of lightning strikes by month is examined in Fig 5.

## VI. CONCLUSION

1. Based on the results from the cloud models it is shown that the ambient electric fields that the wind turbine is subjected

to increase with a decrease in cloud height. Winter clouds which develop at lower altitudes are therefore more capable of developing higher electric fields at ground than those compared to summer clouds.

2. The offshore windfarm data shows that the wind vane instruments are at considerable risk of lightning attachment and that most of these lightning strikes to the wind turbines happen during winter months
3. Results from the FEA wind turbine model follow those of the real lightning strike data, highlighting the windvane and the blades to be the components at the highest risk of lightning attachment.

#### VII. REFERENCE:

- [1] Berger, K., *Novel Observations on Lightning Discharges: Results of Research on Mount San Salvatore*. Journal of the Franklin Institute, 1967. **283**(6): p. 478-525.
- [2] Berger, K. Anderson, and R.B.a. Kröninger, *Parameters of Lightning Flashes*. Cigré, 1975(41): p. 23-37.
- [3] IEC 61400-24, *Wind turbine generator systems – Part 24: Lightning protection for wind turbines* June 2000.
- [4] Cotton, I., et al., *Lightning Protection Of Wind Turbines - A Designers Guide To Best Practice*. 1999.
- [5] Rademakers, L., et al., *Lightning Damage of OWECS*. 2002(Part 1: "Parameters Relevant for Cost Modelling").
- [6] *Project FINO 3* <http://www.fino3.de/Joomla/index.php>, accessed January 2008.
- [7] Sceibe, K., T. Axmann, and C. Birk, *Lightning Research for Offshore Wind Farms in the North Sea*. 29th International Conference on Lightning Protection, 2008.
- [8] McNiff, B., *Wind Turbine Lightning Protection Project NREL Subcontractor Report, SR-500-31115*. 2002.
- [9] Naka, T., et al., *Experimental Studies on Lightning Protection Design for Wind Turbine Blades*. <http://www.jomitek.dk/>, accessed January 2008.
- [10] Sørensen, T., et al., *Lightning Strike Sensor for Power Producing Wind Turbines*. European Wind Energy Conference and Exhibition, Nice, France, 1999..
- [11] Naka, T., et al., *Study on Lightning Protection Methods for Wind Turbine Blades*. IEEJ Transactions, 2005. **125**(10).
- [12] Durstewitz, M., "Wind Energy Report Germany 2001; Annual Evaluation of WMEP"; ISET, Germany. 2001.
- [13] Alonso, M.A. and D.C. Irastorza, *Dynamic Wind Turbine Lightning Protection Behaviour Under Storm Conditions*. 29<sup>th</sup> International Conference on Lightning Protection, 2008.
- [14] Rakov, V.A. and M.A. Uman, *Lightning - Physics and Effects*. 2000.
- [15] Miyake, K., et al., *Winter lightning on Japan Sea coast-lightning striking frequency total structures* IEEE Transactions on Power Delivery, 1990. **Volume: 5**( Issue: 3): p. 1370-1376.
- [16] Bertelsen, K., et al., *Application of numerical models to determine lightning attachment points on wind turbines*. ICLP 2007, 2007.
- [17] Alonso, M.A. and I.A. Larrion, *Calculation of electric fields in a wind mill due to a lightning discharge using finite elements method*.
- [18] Akyuz, M. and V. Cooray, *The Franklin lightning conductor: conditions necessary for the initiation of a connecting leader*. Journal of Electrostatics, 2001. **51**: p. 319-325.
- [19] Broc, A., et al., *Lightning strike to helicopters during winter thunderstorms over North Sea*. Aerospace Science and Technology, 2005. **9**: p. 686-691.

Wind Turbines' a part of the Supergen V Wind Energy Theme



**Ian Cotton** (M'98) was born in the U.K. in 1974. He received a Class I B.Eng. (Hons.) degree in electrical engineering from the University of Sheffield, Sheffield, U.K., in 1995 and the Ph.D. degree in electrical engineering from The University of Manchester Institute of Science and Technology (UMIST), Manchester, U.K., in 1998. He is currently a Senior Lecturer in the Electrical Energy and Power Systems Group, School Of Electrical and Electronic Engineering, University of Manchester. His research interests include power systems transients, the use of higher voltage systems in aerospace applications, and power-system-induced corrosion. His work is based in the University of Manchester HV Laboratories, the largest of any UK University where a 2MV impulse generator, 800kV AC test set and 600kV DC test set is available.

Dr. Cotton is a Senior Member of the Institution of Electrical Engineers and a Chartered Engineer.



**Vidyadhar Peesapati** was born in Edinburgh, U.K, in 1980. He received a Class I B.Eng. degree in electrical and electronics engineering from the University of Madras, Chennai, India in 2001 and the M.Sc. degree in electrical power engineering in 2006 from the University of Manchester, where he is currently pursuing the Ph.D. degree. He is pursuing his Ph.D. on 'Lightning Protection of